

SKIL MODEL 7182 TYPE 1 ORBITAL SANDER

WARNING! Electrical repairs should be attempted only by trained repairmen. Contact the nearest SKIL Service Center or other competent repair service.

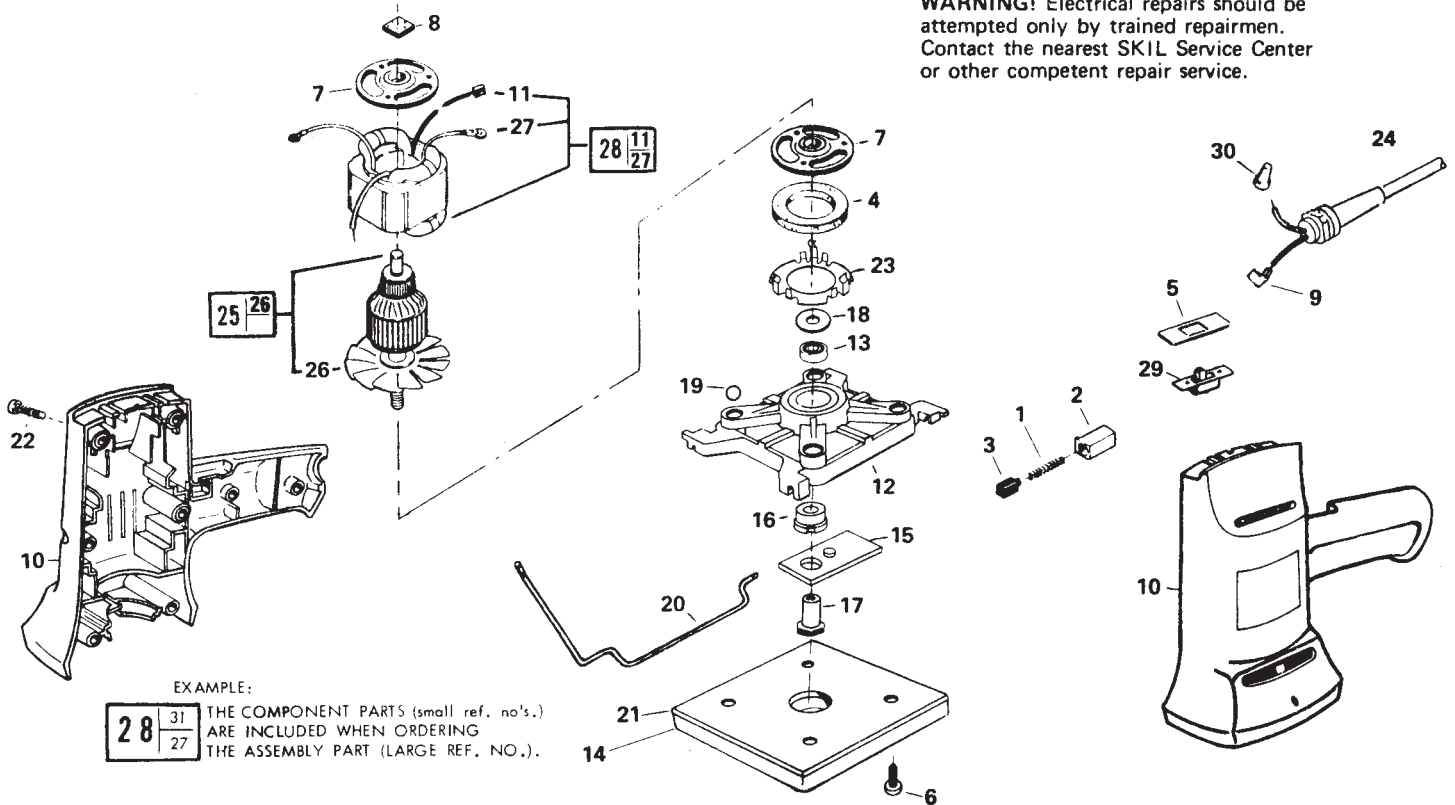

REF. NO.	PART NAME	PART NO.	REF. NO.	PART NAME	PART NO.
1	BRUSH SPRING ... 2	20169	17	HUB NUT	313509
2	BRUSH HOLDER ... 2	20170	18	WASHER	313510
3	BRUSH ... 2	20171	19	BALL ... 4	313514
4	FELT	69628	20	CLAMP ... 2	313516
5	PLATE	69419	21	PLATE	313517
6	SCREW ... 4	300879	22	SCREW ... 8	313518
7	BEARING ASSEMBLY ... 2	301153	23	RETAINER	315257
8	FELT	301168	24 ●	CORD	302815
9	TERMINAL	304129	25	ARMATURE	303191
10	HOUSING SET	321614	26	FAN	313513
11	TERMINAL	320437	27	TERMINAL ... 2	318705
12	BASE	313504	28 ●	FIELD	316519
13	BEARING	15361	29	SWITCH	304055
14 ★	PAD	313506	30 ●	CONNECTOR	304943
15	COUNTERWEIGHT	313507	31	TERMINAL	320437
16	ECCENTRIC	313508			

NOTES:

- ★ ADHESIVE: LOCTITE SUPER BONDER #495 OR EQUAL.
- DO NOT DISCONNECT LEADS FROM THE FIELD. CUT AND SPLICE CORD LEAD TO THE FIELD AS INDICATED.