

PORTER-CABLE GENERATOR

CH350IS

WARNING: Electrical repairs should only be attempted by trained repairman. Contact the nearest Porter-Cable Service Center or other competent repair center.

Parts Identification

1. **Frame Assembly**
 2. **Fuel Tank**
 3. **Fuel Cap**
 4. **6.5 Honda Engine** – Included with this generator is a copy of the Engine Manufacturer Operator Manual. See this manual for more detail on the engine.
 5. **Receptacle-120V Duplex**
 6. **Receptacle 120V-240V Single 4-Prong Twist Lock**
 7. **Outlet 12V/10A DC**- Can be used to charge 12V batteries or operate small 12VDC appliances.
 8. **Circuit Breaker**
 9. **Idle Control Switch**- When in the ON position the engine speed will idle down when no load is on the generator. This will lower the engine noise, save on fuel consumption, and engine life. When in the OFF position engine will run 3600 RPM's continuous with or without a load.
- NOTE:** Allow engine to warm up for approximately 5 minutes before using the idle control.
10. **Full Power Switch**- When placed in the 120V position the maximum surge amps are available for easier starting of large motors.
 11. **Hour Meter** - Measures the number of hours the engine has been run to aid in service scheduling.
 12. **Vibration Isolator**
 13. **Generator Housing**
 14. **Air Filter**
 15. **Grounding Lug** – (not shown) This is the attachment point for a ground wire to an external earth ground.

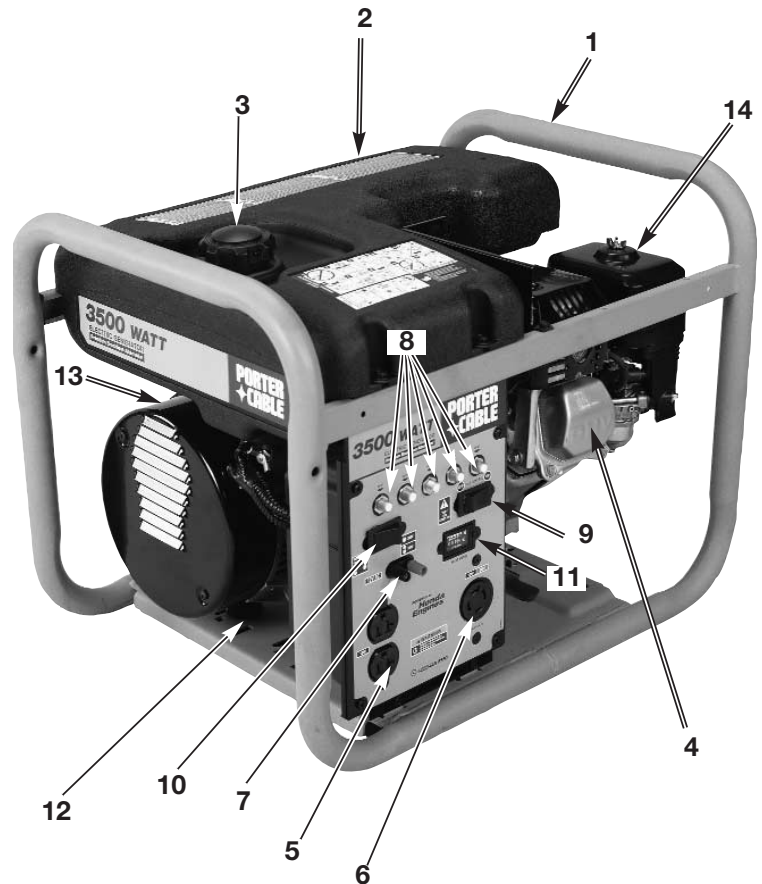

Maintenance and Accessory Parts

Part No.	Qty.	Description
D20870	1	Air Filter
GS-0459	1	Fuel Filter
GS-0225	1	Fuel Line
GS-0227	1	Fuel Line Clamps
GS-0650-1	1	Fuel Tank
GS-0443	1	Fuel Cap
GS-0033	4	Isolators
D20871	1	Spark Arrester (optional)
* GA60	1	Wheel/Handle Kit
91895680	4	Fuel Tank Screws
SSN-632	4	Fuel Tank Washers
BRP6ES (NKG)	1	Spark Plug-May be purchased locally

***Sold Separately**