

PORTER-CABLE GENERATOR

BSI525-W

WARNING: Electrical repairs should only be attempted by trained repairmen. Contact the nearest Porter-Cable Service Center or other competent repair center.

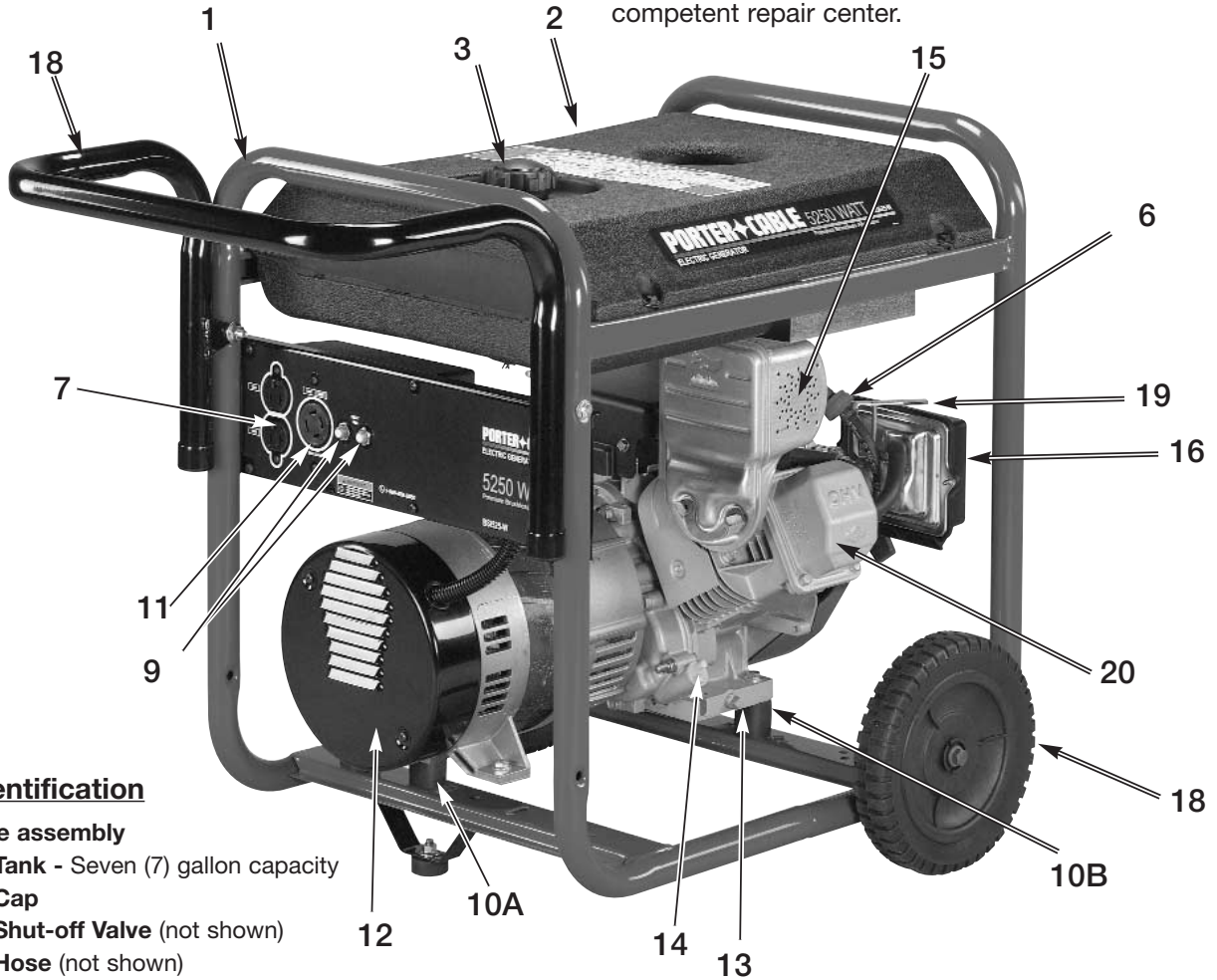

Parts Identification

1. **Frame assembly**
2. **Fuel Tank** - Seven (7) gallon capacity
3. **Fuel Cap**
4. **Fuel Shut-off Valve** (not shown)
5. **Fuel Hose** (not shown)
6. **Fuel Filter**
7. **Receptacle- 120V Duplex**
8. **Grounding Lug-** (not shown) This is the attachment point for a ground wire to an external earth ground.
9. **Circuit Breaker**
- 10A. **Vibration Isolator (GS-0033)**
- 10B. **Vibration Isolator (GS-0433)**
11. **Receptacle- 120/240V 4-Prong Twistlock**
12. **Generator Housing**
13. **Oil Drain Plug**
14. **Oil Fill/Dipstick**
15. **Exhaust Muffler**
16. **Air Filter**
17. **"ON/OFF" Switch** (Not Shown - See Engine Manual)
18. **Wheel/Handle Kit-** Included with this generator to make portability easier.
19. **Choke**
20. **10 HP Briggs & Stratton-** Included with this generator is a copy of the Engine Manufacturer's Operator's Manual. See this manual for more detail on the engine.

Maintenance and Accessory Parts

Part No.	Qty.	Description
GS-0459	1	Fuel Filter
D23219	1	Air Filter
GS-0227	2	Fuel Line Clamps
Z-GS-0225	1	Fuel Line
GS-0433	2	Isolator
GS-0033	1	Vibration Isolator 1.50D x 1.0
Z-GS-0795	1	Gas Tank
91895680	4	Gas Tank Screws (1/4 - 20 x .75)
GS-0443	1	Gas Cap
GA80	1	Wheel/Handle Kit
RC12YC	1	Champion Spark Plug - May be purchased locally