

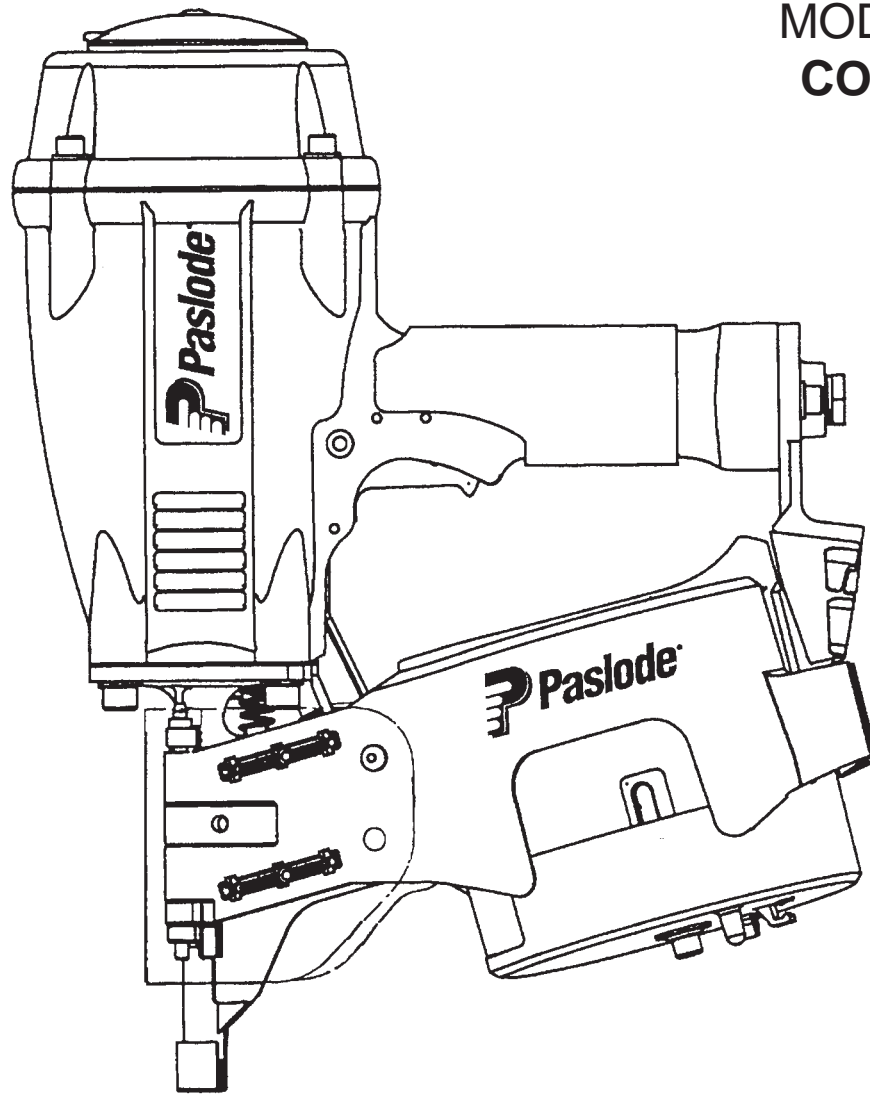

MODEL P350C  
COIL NAILER



TOOL SCHEMATIC AND PARTS

**IMPORTANT!**  
**DO NOT DESTROY**

Always refer to safety and maintenance manual #403606 for detailed information on this tool. It is the customer's responsibility to have all operators and service personnel read and understand this information.

# PARTS LEGEND

**P350-C, 500755**

▲1	501043	1	T.H.S.C.S. 1/4-20 x 1/2"	39	501008	1	Lever, Bottom Trip
2	501016	1	Air Deflector	40	501010	1	Trigger
3	092735	6	S.H.C.S. 1/4-20 x 1-1/4"	41	402669	1	Pin, Trigger
4	092757	8	Flatwasher 1/4"	42	501009	1	Spirol Pin
5	500680	1	Cap	43	263239	1	Retaining Ring
6	501001	1	Gasket, Cap	44	402018	1	End Cap, Feeder Body
7	500754	1	Spacer, Exhaust	45	402084	1	Bumper, Feed Piston
8	500744	1	Stop, Piston	46	402024	1	Spring, Feed Claw Piston
9	500743	1	Spring, Valve	47	500674	1	Feed Claw Piston
10	500742	1	Seat, Spring	*48	402031	1	O-Ring
*11	091986	1	O-Ring	*49	091541	1	O-Ring
*12	092235	2	O-Ring	50	500803	1	Tray Assembly
13	500947	1	Piston Assembly	51	500756	1	Nose
*15	500249	1	O-Ring	52	500715	1	Feed Claw
*16	091864	1	O-Ring	53	402668	2	Retaining Washer
17	500681	1	Sleeve	54	095417	4	Lockwasher
18	500779	1	Flange, Sleeve	▲55	009016	4	S.H.C.S. 5/16-18 x 1"
*19	501002	1	O-Ring	56	500677	1	Hinge Pin
*20	092971	1	O-Ring	57	500700	1	Spring, Feed Claw
21	500745	1	Piston	58	402037	1	Holdback
■*22	402021	1	Driver Blade	59	097748	2	Spring
*23	500866	1	Bumper	60	402486	2	Retaining Washer
24	501023	1	Grip	61	500675	1	Locator
25	091622	1	Reducing Pipe Bushing	62	402487	2	Pivot Pin
26	500746	1	End Cap	63	500817	1	Magazine
*27	092042	1	O-Ring	64	091733	2	Flexloc Thin Nut
28	500739	1	Housing	65	005562	1	F.H.S.C.S. 1/4-20 x 5/8"
29	501018	2	Label, Housing	66	501080	1	Magazine Adjust. Label
30	404663	1	Spring,W.C.E.	67	009041	3	S.H.C.S. 1/4 x 3/4"
31	004224	1	S.H.C.S. 10 -32 x 3/8"	68	500791	1	Nameplate
32	402666	1	Bushing	69	402938	1	Debris Shield
33	008388	1	Flat Washer #10	70	500678	1	Cover, Magazine
34	500758	1	W.C.E.	**71	500492	1	Warning Label
35	071297	3	Roll Pin	72	402655	1	Logo, Magazine
36	097746	1	Valve Pin	73	092174	1	O-Ring
37	401958	1	Valve Body	74	500199	1	Spring
*38	094295	1	O-Ring				

\*

Denotes normal wear items

\*\*

NOTE: Make sure Warning Label (500492) is properly affixed. Replace if necessary. Label available at no charge through Service Department.

▲

Apply Loctite 242 (Blue) Part No. 093500

■

Apply Loctite 680 (Green) Part No. 219241

**AIR CONSUMPTION CHART**

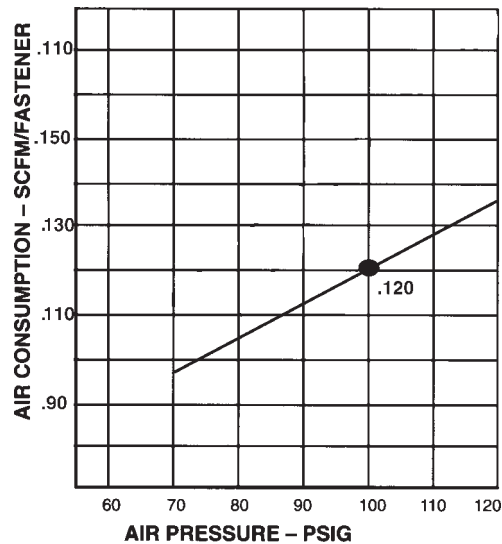

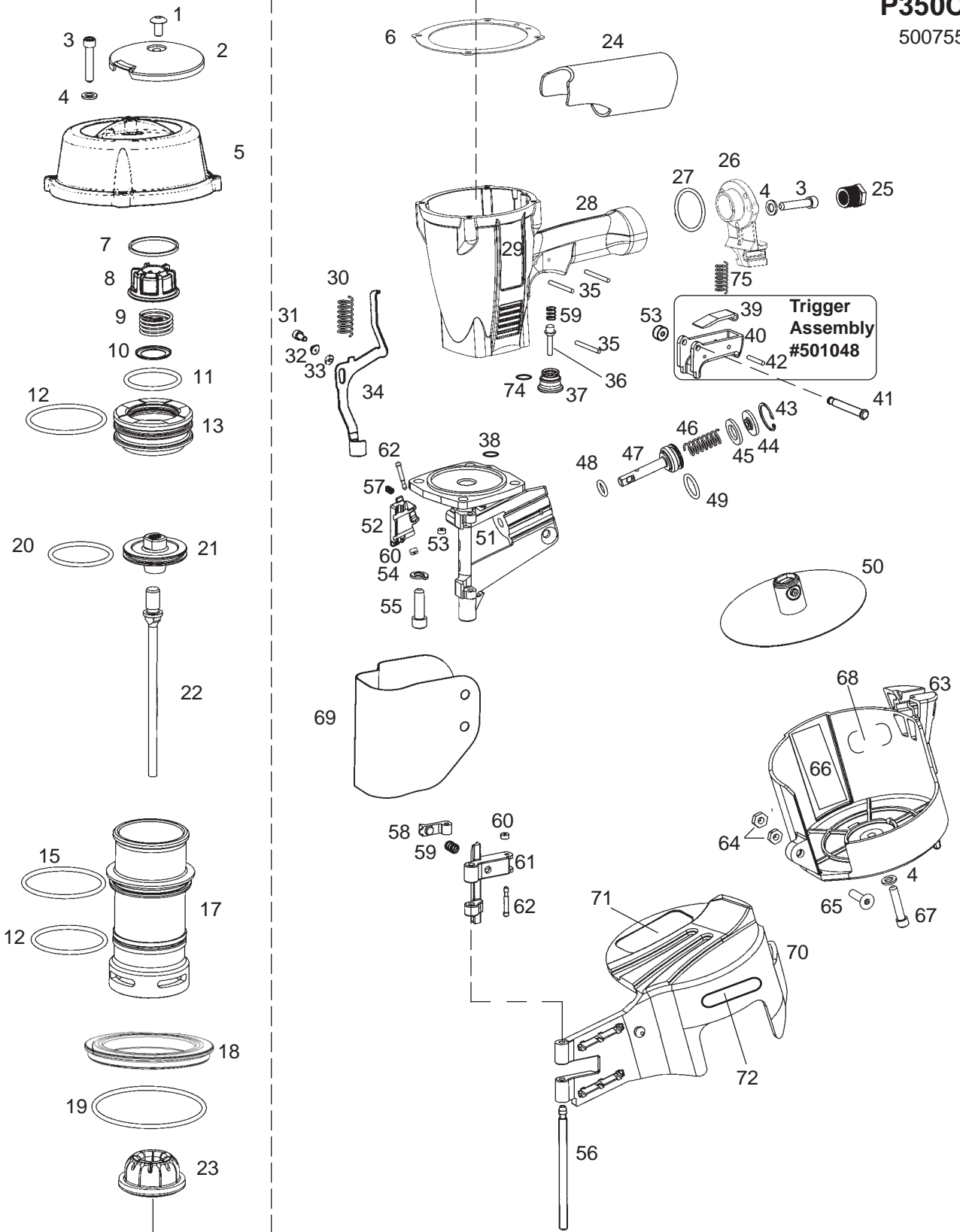

**⚠ WARNING**  
All parts must be periodically inspected and replaced if worn or broken. Failure to do this can affect the tool's operation and present a safety hazard.

# ACCESSORIES

## Sequential Operating Kit

This special attachment is designed for sequential operation (stops "contact" firing). The operator must depress and hold the work contacting element against the work surface before pulling the trigger. This sequence must be repeated each time the tool drives a fastener.

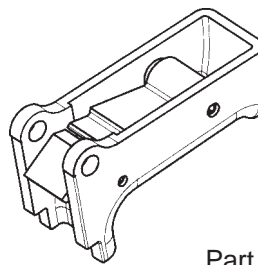

Part No. 501039

## Remote Fire Valve

This valve via a positive air signal allows a machine mounted tool to be operated from an automatic air valve or foot pedal system.

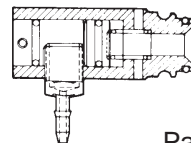

Part No. 1X0713

## Lubricants and Loctite

Loctite 680 (Green)

Part No. 219241

Loctite 242 (Blue) 1 oz.

Part No. 093500

Chemplex 710 Lubricant 1 lb.

Part No. 403734

Lubricating Oil 8 oz.

Part No. 219026

Lubricating Oil 8 oz. with Antifreeze

Part No. 219090

## Degreaser Safety Cleaner

Ideal cleaner for all Paslode tools.

Part No. 219086

## Belt Hook/Hanger

Part No. 219239

## Rafter Hook/Hanger

Part No. 219242

## Combination Rafter-Belt/Hanger

Part No. 501073

## Safety Glasses

Clear

Part No. 402510

Tinted

Part No. 402512

# SAFETY INSTRUCTIONS

## WEAR EYE AND HEARING PROTECTION



Always wear hearing protection and eye protection devices, including side shields when operating or working in the vicinity of a tool.

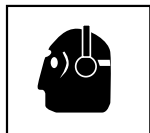

Never use any bottled air or gases such as oxygen to operate the tool since they could cause the tool to explode.

## DO NOT EXCEED MAXIMUM RECOMMENDED AIR PRESSURE

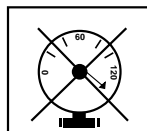

Operate the tool using only the recommended air pressure. Do not exceed the maximum air pressure marked on the tool. Be sure the air pressure gauge is operating properly and check it at least twice a day.

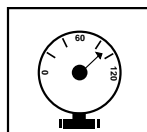

An Illinois Tool Works Company  
888 Forest Edge Drive  
Vernon Hills, Illinois 60061-4503