



SERVICE PARTS LIST

SPECIFY CATALOG NO. AND SERIAL NO. WHEN ORDERING PARTS		REVISED BULLETIN 54-24-0576	DATE Dec. 2000
1-1/8" ROTARY HAMMER			
CATALOG NO.	5303-20	SERIAL NUMBER	893C
		WIRING INSTRUCTION 58-01-1131	

EXAMPLE:

00 0 Component Parts (Small #) Are Included
 When Ordering The Assembly (Large #).

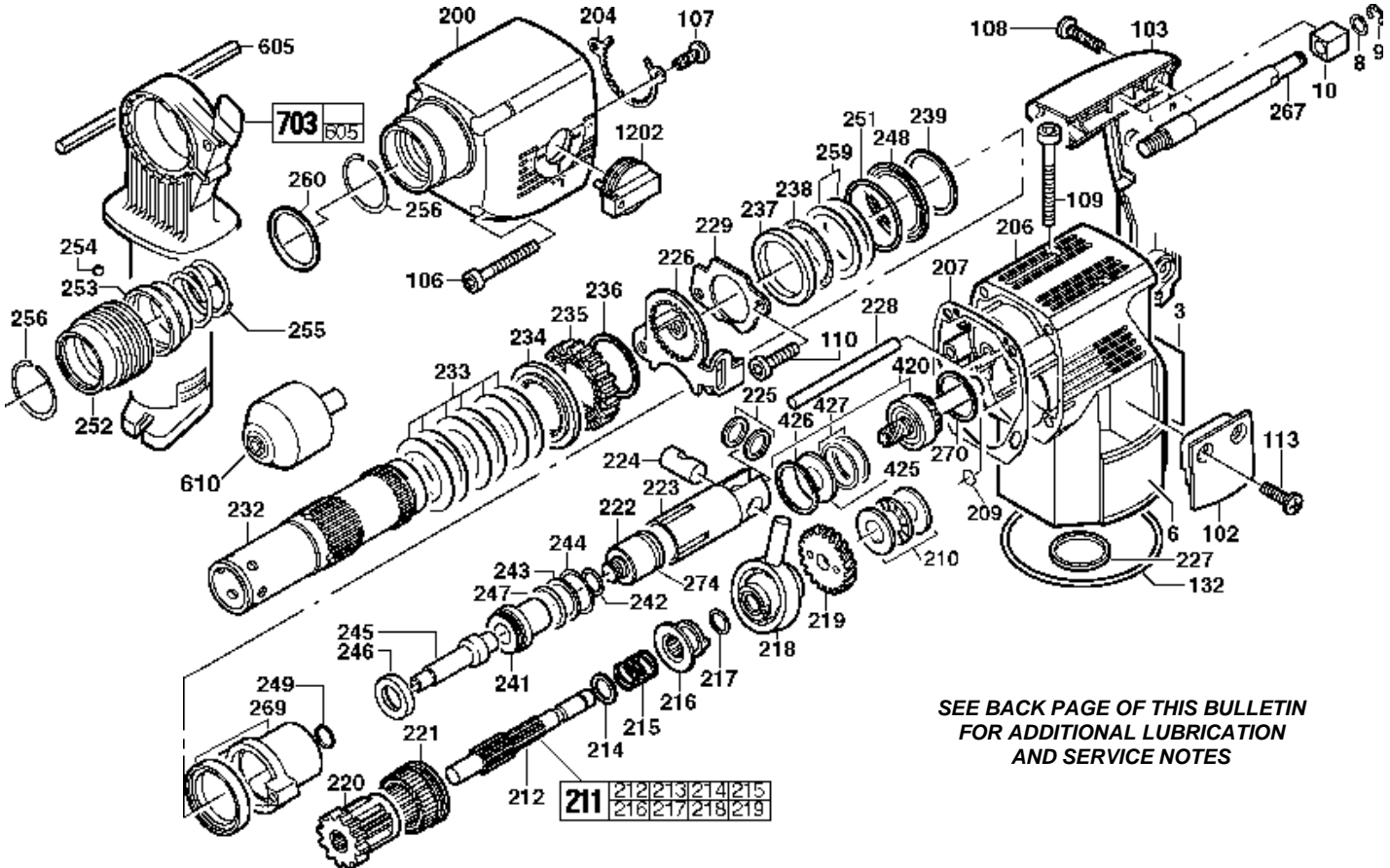

SEE BACK PAGE OF THIS BULLETIN FOR ADDITIONAL LUBRICATION AND SERVICE NOTES

FIG.	PART NO.	DESCRIPTION OF PART	NO. REQ.	FIG.	PART NO.	DESCRIPTION OF PART	NO. REQ.
3	12-20-0407	Nameplate	(1)	238	02-80-0150	Thrust Washer	(1)
6	10-07-6215	Product Label	(2)	239	45-88-0775	Locking Washer	(1)
8	45-88-1245	Washer	(1)	★ 241	44-82-0087	Ram Catcher	(1)
9	44-90-0340	Snap Ring (Ext.)	(1)	242	34-40-4451	O-Ring	(1)
10	43-87-0080	Isolation Block	(1)	★ 243	42-76-0727	Thrust Collar	(1)
102	31-15-0255	Brush Cover	(2)	244	44-90-4415	Retaining Ring	(1)
106	05-74-0685	Screw	(4)	245	45-56-2535	Striker	(1)
107	05-74-0715	Screw	(3)	★ 246	45-88-1262	Washer	(1)
108	05-78-0715	Screw	(2)	247	34-40-4452	O-Ring	(1)
109	05-74-0695	Screw	(2)	248	45-88-1265	Washer	(1)
110	05-74-0700	Screw	(2)	249	34-40-4453	O-Ring	(1)
113	05-78-0745	Screw	(4)	251	34-40-4459	O-Ring	(1)
132	34-40-0145	O-Ring	(1)	252	42-76-0265	Quik Change Collar	(1)
200	31-40-0040	Gearcase	(1)	253	44-90-0105	Ring	(1)
204	44-86-0625	Splined Retainer	(1)	254	02-02-0100	Ball	(6)
206	31-15-0305	Crankcase	(1)	255	40-50-8900	Spring	(1)
207	43-44-0375	Gasket	(1)	★ 256	44-90-0350	Snap Ring (Ext.)	(2)
209	34-40-4440	O-Ring	(1)	259	45-88-1270	Washer	(2)
210	02-80-6025	Thrust Bearing Set	(1)	260	45-88-1275	Washer	(1)
211	14-73-0246	Wobble Shaft Assembly	(1)	267	05-77-0030	Bolt	(1)
212	36-66-3160	Reduction Gear Shaft	(1)	269	45-60-0511	Spindle Bearing Support	(1)
214	45-88-1250	Washer	(1)	270	44-90-0115	Ring	(1)
215	40-50-8895	Spring	(1)	274	34-40-4465	O-Ring	(1)
216	45-22-0300	Coupling Sleeve	(1)	420	36-66-4266	Intermediate Gear Set	(1)
217	45-88-1240	Washer	(1)	★ 425	45-88-0790	Washer	(1)
218	36-92-0745	Wobble Plate	(1)	426	45-88-1170	Retaining Ring	(1)
219	32-60-2621	Reduction Gear	(1)	427	45-88-1175	Shim Washer	(2)
220	32-60-2155	Offset Gear	(1)	605	43-46-0170	Depth Gauge	(1)
221	32-60-2165	Internal Gear	(1)	★ 610	48-66-3042	Quik Change SDS-Plus Chuck	(1)
222	44-82-0190	Ram	(1)	700	48-55-5303	Carrying Case	(1)
223	44-62-0155	Piston	(1)	703	49-15-0305	Side Handle w/Depth Rod	(1)
224	44-60-1405	Wrist Pin	(1)	1202	44-10-0075	Shift Lever	(1)
225	45-88-1180	Washer	(2)		10-15-0270	Warning Tag	(1)
226	44-90-4500	Shift Ring	(1)		14-46-5303	Lubrication Service Kit	(1)
227	34-40-4454	O-Ring	(1)				
228	44-60-1485	Pin	(1)				
229	44-66-6055	Retaining Plate	(1)				
★ 232	38-50-0037	Spindle	(1)				
233	40-50-7975	Belleville Spring	(6)				
234	45-88-7765	Stop Washer	(1)				
235	32-75-1205	Spindle Gear	(1)				
236	44-90-4510	Retaining Ring (Ext.)	(1)				
237	45-88-1255	Washer	(1)				

FIG.	PART NO.	DESCRIPTION OF PART	NO. REQ.
4	22-64-0505	Cord Set	1
5	44-76-0285	Strain Relief	1
7	44-60-0015	Grooved Dowel Pin	1
100	31-50-0955	Motor Housing	1
101	31-15-0440	Motor Cover	1
103	31-44-2100	Handle Set	1
105	18-07-0121	Field - Service	1
111	05-74-0705	Screw	4
112	05-78-0720	Screw	2
114	05-78-0715	Screw	4
115	42-96-0170	Bearing Cup	1
116	31-05-0220	Air Deflector Ring	1
117	45-30-0210	Vinyl Slug	4
120	22-20-0230	Brush Holder	2
123	42-70-1100	Field Centering Clip	2
125	31-17-0240	Cord Clamp	1
127	45-30-0220	Slug	2
128	23-94-1035	Wire	1
129	23-94-1040	Wire	1
130	42-92-0015	Bearing Cover	1
135	23-66-1685	Switch	1
406	16-07-0121	Armature	1
407	22-84-0940	Fan	1
408	02-04-1800	Ball Bearing	1
409	02-04-1815	Ball Bearing	1
410	43-06-0135	Insulating Disc	1
411	44-90-4405	Retaining Ring	1
413	45-22-0465	Sleeve	1
414	45-36-1595	Spacer	1
420	36-66-4266	Intermediate Gear Set	1
1201	22-18-0940	Brush (2) Service Kit	1

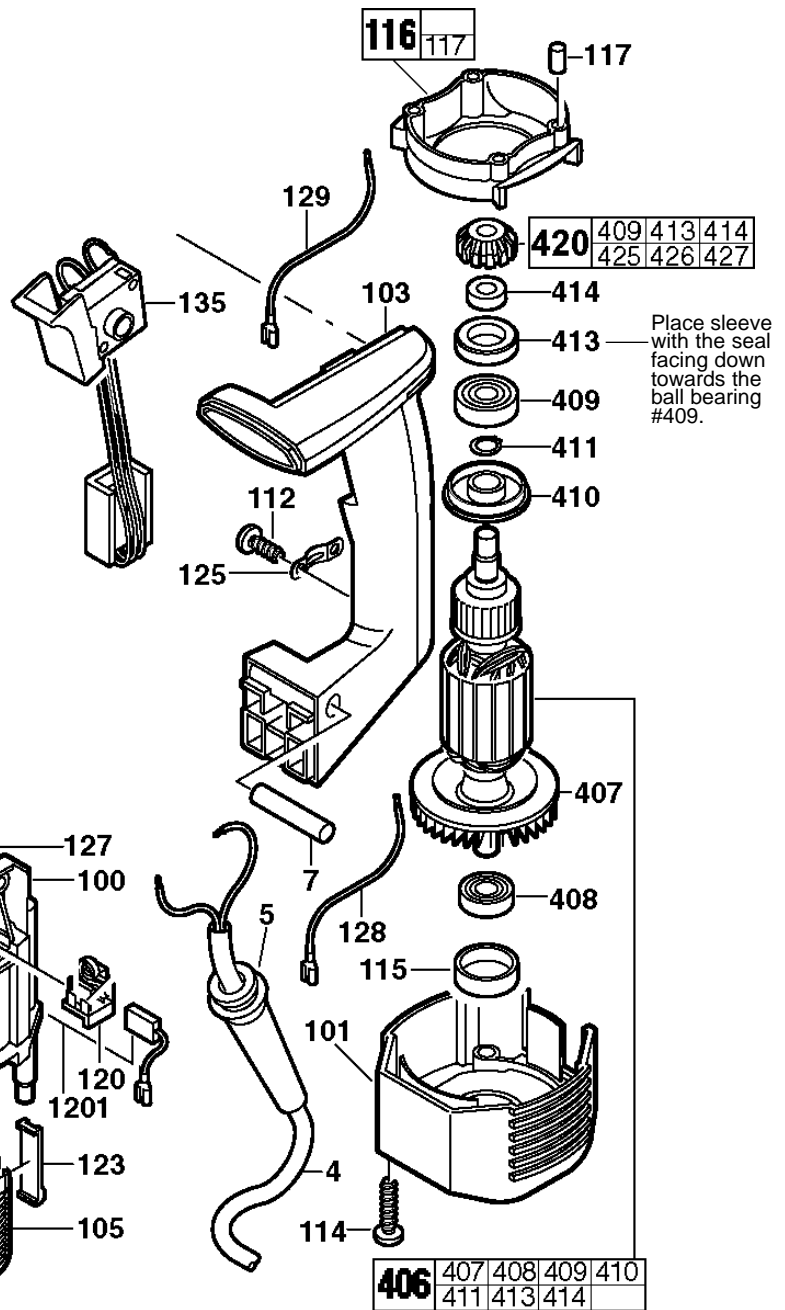

**SEE BACK PAGE OF THIS BULLETIN
FOR ADDITIONAL LUBRICATION
AND SERVICE NOTES**

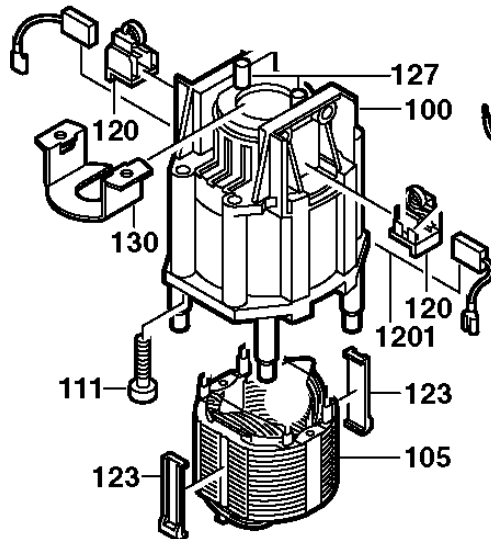

Service Kit 14-46-5303 Contains:

Qty.	Cat. No.	Description	Qty.	Cat. No.	Description
1	49-08-4250	Type "P" Grease (1.5 oz.)	1	34-40-4452	O-Ring
1	49-08-4255	Type "Q" Grease (1.5 oz.)	1	44-90-4415	Retaining Ring
1	44-76-0285	Strain Relief	1	34-40-4459	O-Ring
1	43-87-0080	Isolation Block	1	42-76-0265	Quik Change Collar
2	42-96-0170	Bearing Cup	1	34-40-4465	O-Ring
1	43-44-0375	Gasket	1	22-18-0940	Brush Service Kit (2)
2	45-88-1180	Washers	1	44-10-0075	Shift Lever
2	34-40-4454	O-Ring	2	05-81-0932	Switch Screws
1	34-40-4451	O-Ring	1	45-30-0055	Silicone Slug

SERVICE NOTES:

5303-20

1. For any service that requires access into the gearcase, the shift lever must be removed. To remove, shift to the hammer and drill mode and insert a screwdriver under the lever end and pry up. The lever will be destroyed and must be replaced.
2. To remove the gearcase, remove the retaining ring (256) with special pliers 46-59-9057 and remove it with the gearcase.
3. To remove the spindle, the two mounting bolts (110) must be removed with a metric allen wrench.
4. To remove the ram, tap the end of the striker with a hammer, this frees the ram from the ram catcher.
5. To remove the ram catcher, striker and striker support from the spindle, remove the internal retaining ring with a small screwdriver by pushing on the ring through the two small ports in the spindle where the ring is visible. Push the ring in and towards the open end of the spindle. Press out all internal parts.
6. To remove the rear thrust bearing, remove the spiral lock retaining ring with a screwdriver and then remove the thrust bearing.
7. To remove the spindle gear/clutch, press the spindle gear against the disk springs and remove the retaining ring that fits into the gear counter bore. Once this retaining ring is removed, all of the parts will slip off of the spindle.
8. To remove the wobble shaft, turn the shaft so the wobble finger leans toward the motor housing. Pull out on the shaft, tilt and wiggle it to get it to clear the crankcase.
9. To disassemble the wobble shaft, remove the retaining ring by the drive gear. Press the drive gear off, remove all remaining parts.
10. To remove the bearing housing (269), try turning it by twisting on the lugs by hand. If it can be moved, continue to twist and pull to remove. If it will not move, it must be removed with an internal bearing puller.
11. When removing the intermediate shaft, note the number of shim washers that are between the snap ring and the bearing. Be sure to return them all when reassembling the tool.
12. To remove the handle, push out dowel pin (7), open handle, remove snap ring and washer from anti-vibration rubber mount, disconnect field leads under motor cover and remove handle.
13. To remove motor, remove two screws from the top of the crankcase and four screws (111) from deep pockets in motor housing (100). Slide motor and motor housing out of crankcase.
14. To remove armature from motor assembly, pull brushes off of commutator, slide bearing cover (130) from under bearing, slide armature out.
15. When reassembling bearing housing (269) to crankcase do not press it completely into place before the piston and wobble shaft are in place.
16. Shim washers (427) as required, maximum of 2.

17. When reassembling the wobble shaft, a clearance of .001 to .003 inch must be maintained between the drive gear and the inner race of the wobble plate. The ground side of the gear must face the wobble plate.

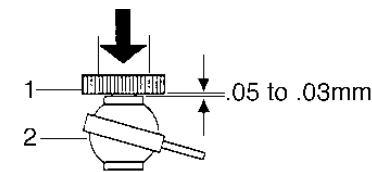

18. Before assembling wobble shaft to crankcase, assemble the loose rollers that support the drive gear end of the wobble shaft in their shell in the crankcase. Hold the rollers in place with grease. (Tool may not have loose rollers)

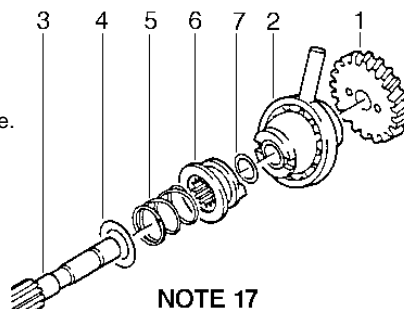

NOTE 17

19. When reassembling the clutch be sure to stack the disk springs as shown.

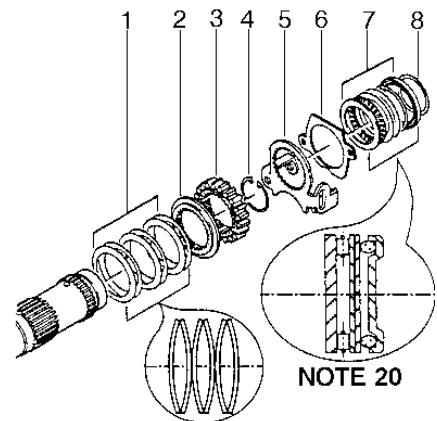

NOTE 19

NOTE 20

20. Thrust bearing on spindle must be assembled as shown.

21. To push the internal retaining ring into the spindle that retains the striker, striker support and ram catcher, use an old, used piston. The position of the ring can be visually checked by looking in the removal ports.

22. Seal of item (413) to face bearing.

23. Check items (117 and 127), replace if worn or missing.

24. Bearing Cup (115) to be placed in motor cover (101) before assembly.

SEE BACK PAGE OF THIS BULLETIN FOR ADDITIONAL LUBRICATION AND SERVICE NOTES

**GREASING INSTRUCTIONS:
5303-20**

Type "P" Grease (Cat. No. 49-08-4250)

1. Place 1/2 oz. at needle bearing / splined retainer area of gear case.
2. Grease assembled wobble shaft with 1/2 oz. of grease.
3. Place 1/8 oz. in armature pinion / intermediate shaft assembly (420) cavity.
4. Place 1/4 oz. of grease in wobble shaft drive gear cavity of crankcase.
5. Grease clutch and clutch springs on spindle with 1/8 oz. of grease.

NOTE: Total amount used; 1 1/2 oz. (one complete tube)

Type "Q" Grease (Cat. No. 49-08-4255)

1. Coat the spindle inside and out.
2. Coat all parts assembled on or in spindle except for clutch.
3. Coat piston (inside and out), ram, wrist pin and wrist pin washers or sliding bow. DO NOT coat the flat face of the ram.

NOTE: Total amount used; 3/4 oz. (1/2 of a full tube)

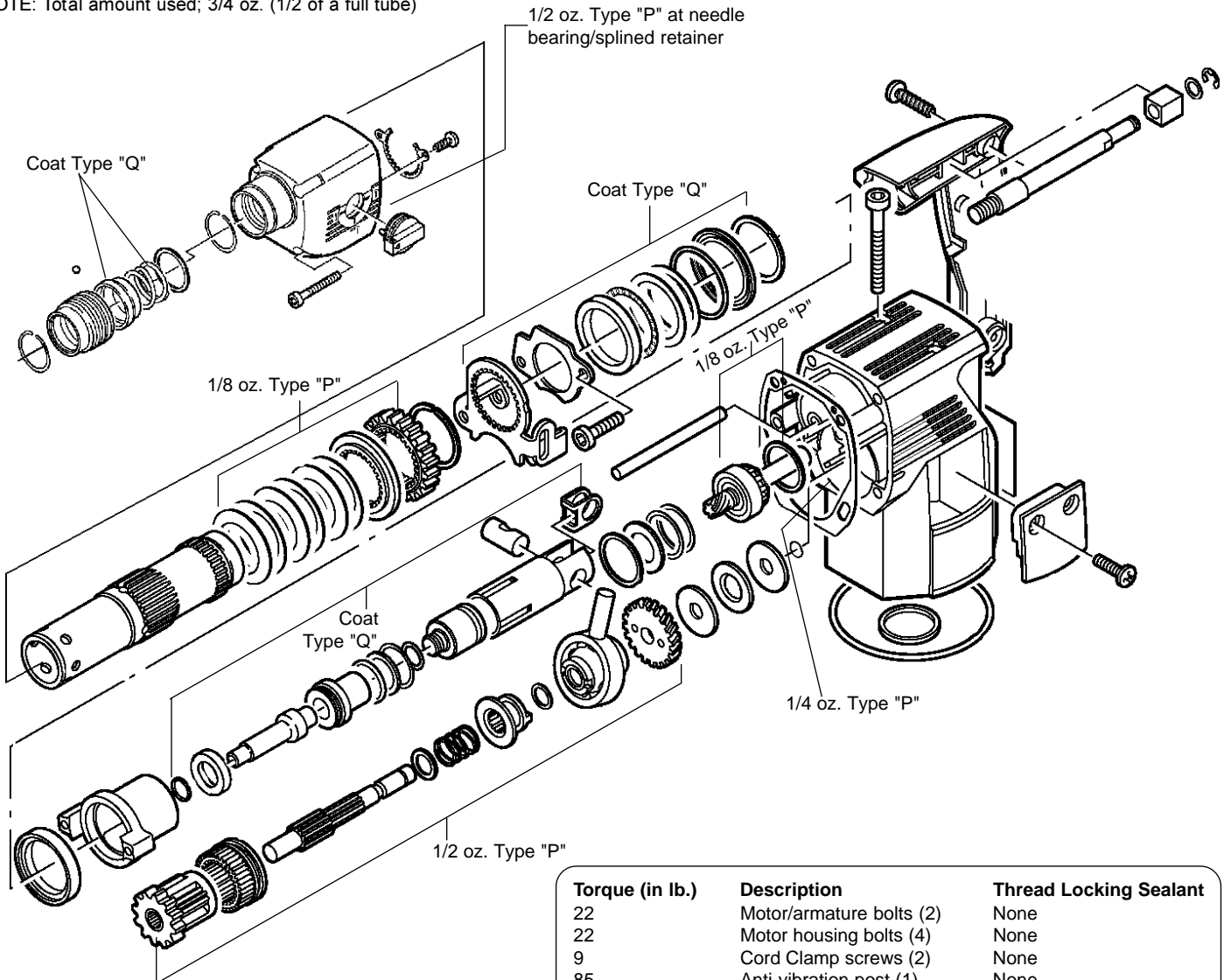

Torque (in lb.)	Description	Thread Locking Sealant
22	Motor/armature bolts (2)	None
22	Motor housing bolts (4)	None
9	Cord Clamp screws (2)	None
85	Anti-vibration post (1)	None
10	Handle screws (3)	None
16	Motor cover screws (4)	None
50	Spindle retaining bolts (2)	Blue
22-26	Gearcase screws (4)	None