



SERVICE PARTS LIST

BULLETIN NO.
54-42-5856

SPECIFY CATALOG NO. AND SERIAL NO. WHEN ORDERING PARTS		REVISED BULLETIN	DATE
SCREW-SHOOTER MAGAZINE ATTACHMENT & EXTENSION KIT		54-42-5855	Nov. 2003
CATALOG NO. 48-05-1005	DATE CODE	WIRING INSTRUCTION	
	011901022		

00
0

EXAMPLE:
Component Parts (Small #)
Are Included When Ordering
The Assembly (Large #).

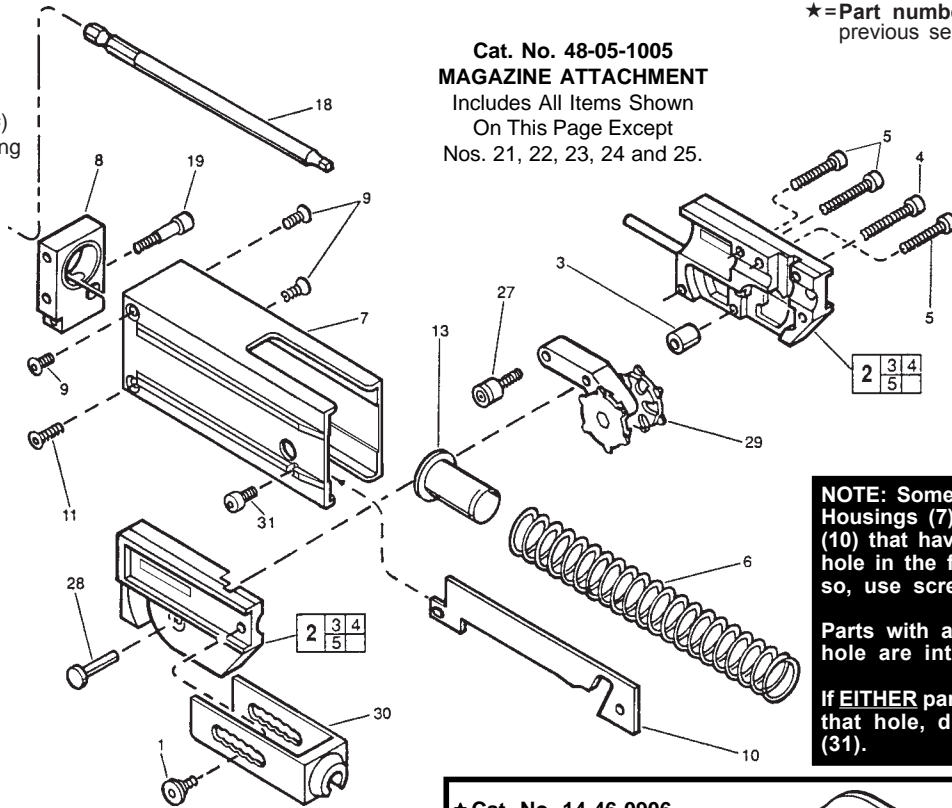

★=Part number change from previous service parts list.

Cat. No. 48-05-1005
MAGAZINE ATTACHMENT

Includes All Items Shown
On This Page Except
Nos. 21, 22, 23, 24 and 25.

NOTE: Some units may have Housings (7) AND Curve Plates (10) that have a small tapped hole in the front, as shown. If so, use screw (31).

Parts with and without the hole are interchangeable.

If EITHER part DOES NOT have that hole, disregard screw (31).

FIG.	PART NO.	DESCRIPTION OF PART	NO. REQ.
1	06-81-1700	M5 x 0.8 x 5. lg, 3mm Skt. Hd. Slid. Sc.	2
★ 2	43-56-0315	Gliding Assembly (Incl. 3,4,5)	1
3	42-40-0001	Distance Bearing Bushing	1
★ 4	06-95-1000	M3.5 x 22. lg, Phillips Pan Hd. Plast. Sc.	1
★ 5	06-95-1005	M3.5 x 24. lg, Phillips Pan Hd. Plast. Sc.	3
6	40-50-0406	Spring (Green or Yellow)	1
7	43-76-0052	Housing	1
8	44-66-1500	Mounting Plate	1
9	06-81-2000	M4 x 0.7 x 8. lg, 2.5mm Skt. Hd. Flat Sc.	3
10	44-66-0306	Curve Plate	1
11	06-81-2005	M4 x 0.7 x 10. lg, 2.5mm Skt. Hd. Flat Sc.	1
13	43-56-0300	Spring Guide	1
★ 18	48-30-1527	140mm #2 Square Bit	1
★ 18A	48-30-1528	140mm #2 Phillips Bit	1
19	06-81-2010	M5 x 0.8 x 25. lg, 4mm Skt. Hd. Slid. Sc.	1
27	06-81-2025	M5 x 0.8, 3mm Socket Hd. Roller Screw	1
28	44-60-1520	Pivot Pin	1
29	42-74-0095	Gear Wheel Unit	1
★ 30	43-46-0208	Depth Control, 1-1/4" to 3"	1
★ 31	06-81-2045	M4 x 0.6mm x 2.5mm Skt. Hd. Cap Scr.	1
	49-96-4800	Hex Key Set-2, 2.5, 3 & 4mm (Not Shown)	1
	10-15-6100	Depth Label (Not Shown)	1
	12-25-1470	Warning Label (Not Shown)	1

FIG. NOTES:
9,11 Use Loctite 272 on screws.

SEE REVERSE SIDE FOR 20.5" EXTENSION PARTS

★ **Cat. No. 14-46-0906**
2 BEND BELT
GUIDE ASSEMBLY
(Not Included With
48-05-1005 Screw-Shooter
Magazine Attachment)

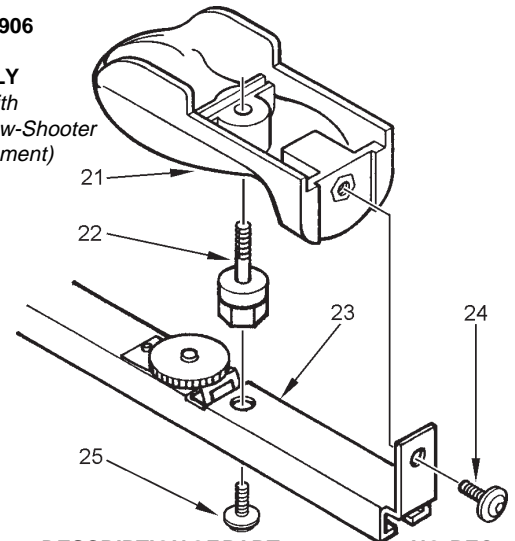

FIG.	PART NO.	DESCRIPTION OF PART	NO. REQ.
21	43-62-1230	Handle	1
★ 22	06-75-0400	Shoulder Bolt	1
23	-----	2 Bend Belt Guide	1
24	06-81-2020	M5 x 0.8 x 12. lg, 4mm Skt.1 Hd. Pan Sc.	1
★ 25	06-81-2035	M5 x 0.8 x 10. lg, 3mm Skt. Hd. Sc.	1

For Short Configuration (No Extension)

The Following Parts Are Required:

★	14-46-0906	2 Bend Belt Guide Assembly	1
★	43-76-0296	Adapter Assembly	1
	43-72-0010	Bit Holder	1

NOTE: Parts For Short Configuration Are Not Included With 48-05-1005 Screw-Shooter Magazine Attachment.

MILWAUKEE ELECTRIC TOOL CORPORATION
13135 W. LISBON RD., BROOKFIELD, WI 53005

20.5" EXTENSION PARTS

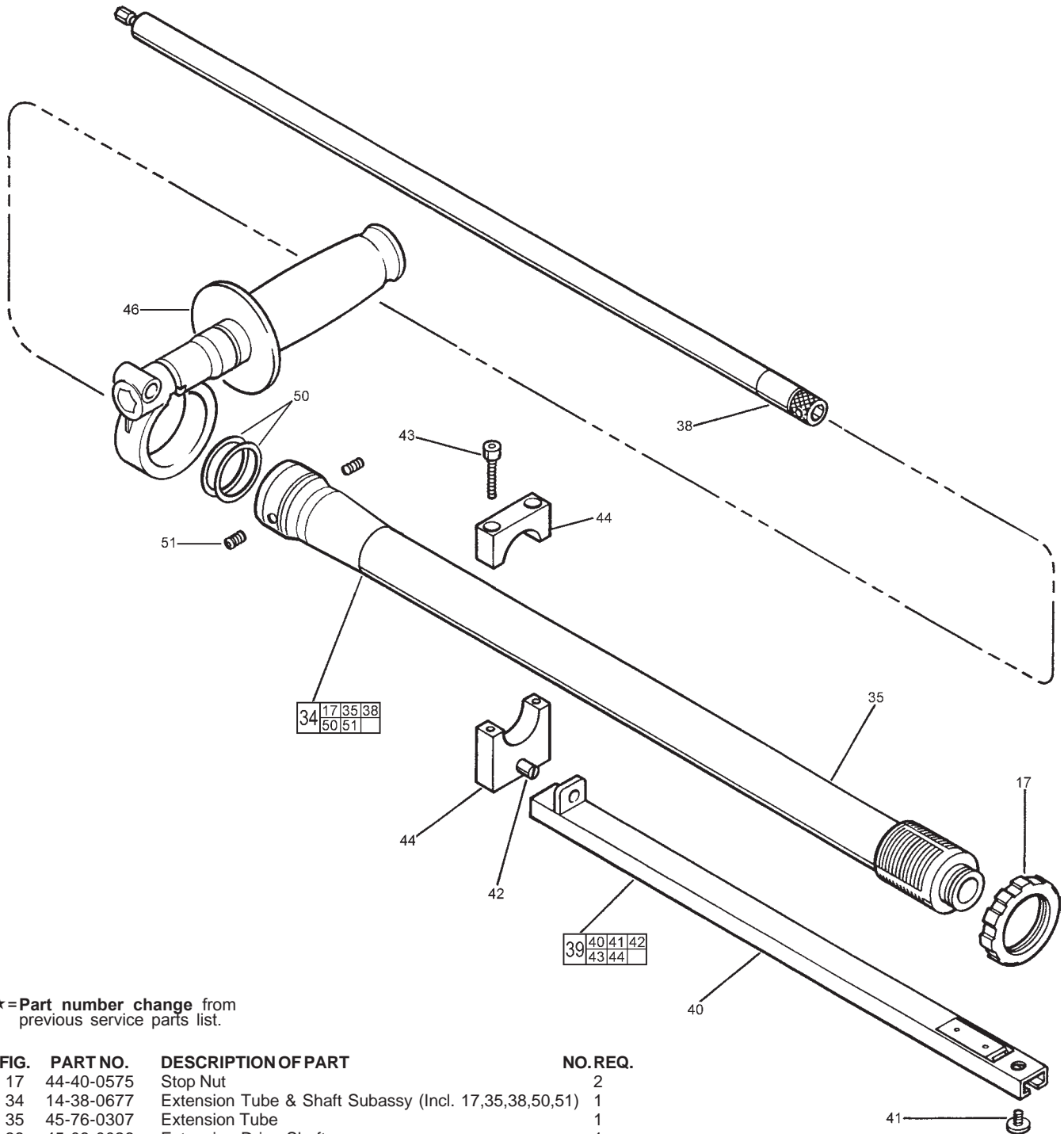

★=Part number change from previous service parts list.

FIG.	PART NO.	DESCRIPTION OF PART	NO. REQ.
	17	44-40-0575 Stop Nut	2
★	34	14-38-0677 Extension Tube & Shaft Subassy (Incl. 17,35,38,50,51)	1
★	35	45-76-0307 Extension Tube	1
	38	45-08-0026 Extension Drive Shaft	1
	39	14-38-0685 Screw Guide Subassembly (Incl. 40,41,42,43,44)	1
	40	----- Screw Guide	1
	41	06-81-2035 M5 x 0.8 x 10. lg, 3mm Socket Hd. Screw	1
	42	43-56-0330 Slotted Guide Screw	1
	43	06-81-2040 M4 x 0.7 x 25. lg, 3mm Socket Hd. Screw	2
	44	----- Clamp	1
★	46	14-34-0506 Side Handle Subassembly	1
	50	34-40-0700 30 x 25 x 2.5mm O-Ring	2
	51	06-83-1400 M6 x 1.0 x 6 lg, 3mm Socket Hd. Set Screw	2