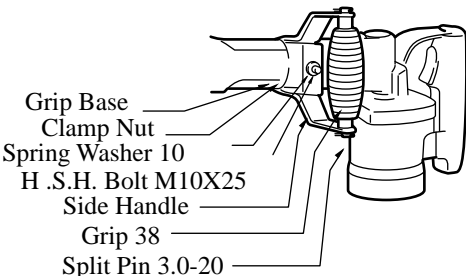
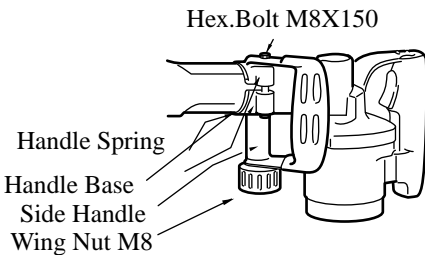

Item No.	Part No.	Qty. Used	Description	Item No.	Part No.	Qty. Used	Description
1	151310-9	1	BARREL COMPLETE	51	953106-2	4	RIVET 0-5
2	922451-6	4	HEX. SOCKET HEAD BOLT M8X30	53	159034-1	1	MOTOR HOUSING
3	213655-4	1	O RING 56	54	643650-4	2	BRUSH HOLDER CAP 6.5-13.5
4	321732-9	1	STRIKER	55	181048-2	1	A.C. CARBON BRUSH CB-155
5	412049-2	1	PISTON RING 40	56	284055-5	1	REAR COVER
6	341862-0	1	INNER RING 36	57	942101-7	2	SPRING WASHER 5
7	412049-2	1	PISTON RING 40	58	922222-1	2	HEX. SOCKET HEAD BOLT M5X16
8	341862-0	1	INNER RING 36	59	922371-4	4	HEX. SOCKET HEAD BOLT M6X50
9	256120-0	1	PIN 10	60	941151-9	4	FLAT WASHER 6
10	150041-7	1	CRANK CAP COMPLETE	61	931302-2	1	HEX. NUT M6
11	213754-2	1	O RING 71	62	942151-2	1	SPRING WASHER 6
12	315419-3	1	CONNECTING ROD	63	941151-9	1	FLAT WASHER 6
13	212208-6	1	NEEDLE BEARING 1516	64	911243-8	2	PAN HEAD SCREW M5X25
14	152180-9	1	CRANK SHAFT COMPLETE	66	182564-7	1	HANDLE SET INC. 79
15	254001-2	1	WOODRUFF KEY 4	67	911129-6	1	PAN HEAD SCREW M4X16
16	962251-2	1	RETAINING RING R-52	68	651145-3	1	SWITCH C3D-H-MS
17	211327-5	1	BALL BEARING 6304LLU	69	421265-5	1	DUST COVER
18	213656-2	1	O RING 53	70	*	1	GRIP 38
19	156863-3	1	CRANK HOUSING COMPLETE INC. 18	71	*	1	HEX. BOLT M8X150
20	213306-9	1	OIL SEAL 20	72	*	1	SIDE HANDLE
21	221701-9	1	HELICAL GEAR 50	73	*	1	CLAMP NUT
22	211209-1	1	BALL BEARING 6202	74	*	1	HANDLE BASE 60
23	256111-1	1	PIN 6	75	*	1	SPRING WASHER 10
24	157799-9	1	GEAR HOUSING	76	*	1	H.S.H. BOLT M10X25
25	321441-0	1	PISTON	77	922316-2	2	HEX. SOCKET HEAD BOLT M6X14
26	267059-2	1	FLAT WASHER 32	78	343755-7	2	CUSHION PLATE
27	261054-4	1	NYLON WASHER 32	79	182564-7	1	HANDLE SET INC. 66
28	253845-7	1	FLAT WASHER 31	80	321210-9	1	HANDLE SHAFT
29	213604-1	1	O RING 50	81	682567-6	1	CORD GUARD 8
30	322569-7	1	IMPACT BOLT	82	664658-5	1	POWER SUPPLY CORD AWG#18-3-5.0
31	213472-2	1	X RING 35	83	687001-1	1	STRAIN RELIEF
32	213464-1	1	O RING 34	84	911133-5	2	PAN HEAD SCREW M4X18
33	256219-1	1	PIN 4	87	265914-2	2	HEX. SOCKET HEAD BOLT M6X25
34	322570-2	1	TOOL RETAINER	88	257636-8	2	SLEEVE 6
35	322571-0	1	TOOL HOLDER	89	262052-1	2	RUBBER RING 9
36	922451-6	4	HEX. SOCKET HEAD BOLT M8X30	90	262051-3	2	RUBBER RING 9
37	231281-7	1	COMPRESSION SPRING 15	91	*	1	HANDLE SPRING 60
38	322699-4	1	RETAINER RING	92	*	1	WING NUT M8
39	331180-4	1	SEAL	93	**	1	HANDLE BASE 60
40	213460-9	1	O RING 35	B01	***	1	SIDE HANDLE ASS'Y INC. 71,72,74,91,92,93
41	211206-7	1	BALL BEARING 6202LLB				
42	213202-1	1	DUST SEAL 15				
43	241638-4	1	FAN 94				
44	514776-8	1	ARMATURE ASS'Y 115V INC. 41-43,45,46				
45	681635-2	1	INSULATION WASHER				
46	211087-9	1	BALL BEARING 6200DDW				
47	213406-5	1	O RING 30				
48	410163-8	1	BAFFLE PLATE				
49	265347-1	2	+ HEX. BOLT M5X45				
50	524631-6	1	FIELD ASS'Y 115V				

SERVICE CHANGES

1. Changes on Side Handles.

▶ TYPE 1	▶ TYPE 2
 <p>Grip Base Clamp Nut Spring Washer 10 H.S.H. Bolt M10X25 Side Handle Grip 38 Split Pin 3.0-20</p> <p>Hex. Wrench 8 is necessary to loosen/tighten Hex. Socket Head Bolt for adjustment of the grip position.</p>	 <p>Hex.Bolt M8X150 Handle Spring Handle Base Side Handle Wing Nut M8</p> <p>The Side Handle can be swivelled by loosening Wing Nut M8 and can be fixed in suitable position by tightening it. And Hex. Wrench 8 is now unnecessary and removed from standard equipment.</p>

Interchangeability(I/C)

Item No.	TYPE 1	Q'ty	I/C	TYPE 2	Q'ty	Note
72	Side Handle 343322-8 (Discontinued)	1	No	Side Handle 416009-6 (See Service Change #3)	1	↑ Interchangeable as a set ↓
74	Grip Base 343321-0 (Discontinued)	1		Handle Base 60 416010-1 (See Service Change #2)	2	
73	Clamp Nut 321949-4 (Discontinued)	1				
70	Grip 38 273490-2 (Discontinued)	1				
71	Split Pin 3.0-20 952257-8	2		Hex. Bolt M8X150 265439-6	1	
76	Hex. Socket Head Bolt 922542-3 (Discontinued)	1				
75	Spring Washer 10 942251-8	1				
91				Handle Spring 60 344379-2 (See Service Change #2)	1	
92				Wing Nut M8 252640-2	1	
401	Hex. Wrench 8 783210-1 (Discontinued)	1				

2. Change of Handle Spring and Handle Base

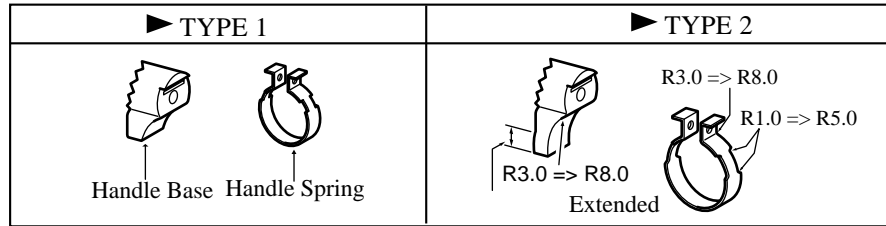

Interchangeability(I/C)

Item No.	TYPE 1	Q'ty	I/C	TYPE 2	Q'ty	Note
71	Handle Spring 60 344379-2 (Discontinued)	1	No	Handle Spring 60 344559-0 (See Service Change #3)	1	Interchangeable as a set
	Handle Base 60 416010-1 (Discontinued)	2	No	Handle Base 60 416396-3 (See Service Change #3)	2	

3. Modification of D-Shaped Side Handle

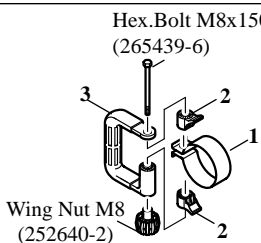
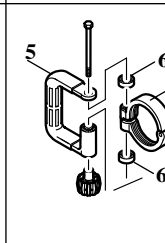
▶ TYPE 1	▶ TYPE 2
 <p>Hex.Bolt M8x150 (265439-6)</p> <p>Wing Nut M8 (252640-2)</p> <ol style="list-style-type: none"> 1. Handle Spring 60 (344559-0) Material: Sheet Metal 2. Handle Base 60 (416396-3) [2 pcs.] Material: Resin 3. Side Handle (416009-6) 	 <ol style="list-style-type: none"> 4. Side Handle Base 60 Cpl. (152620-7) Material: Aluminum 5. Side Handle (417003-1) 6. Side Handle Cam (417002-3) [2 pcs.]
<p>Side Handle Assembly (134793-8) It consists of the six parts illustrated above.</p>	<p>Side Handle Assembly (134909-5) It consists of the six parts illustrated above.)</p>

Interchangeability(I/C)

Item No.	TYPE 1	Q'ty	I/C	TYPE 2	Q'ty	Note
See below	Side Handle 416009-6 (Discontinued)	1	No	Side Handle 417003-1	1	Interchangeable as a set
	Handle Spring 60 344559-0 (Discontinued)	1	No	Side Handle Cam 417002-3	2	
	Handle Base 60 416396-3 (Discontinued)	2		Side Handle Base 60 CPL. 152620-7	1	Interchangeable as a set
	Side Handle Assembly 134793-8 (Discontinued)	1	Yes	Side Handle Assembly 134909-5	1	

Item No.

TYPE 1	TYPE 2	HM1211B
Side Handle	Side Handle	072
	Side Handle Cam	074, 093
Handle Spring 60	Side Handle Base 60 Comp.	091
Handle Base 60		072,093