

PNEUMATIC TOOL PARTS LIST

■ FINISH NAILER

2003 • 8 • 5

Model NT 65MA2

(E1)

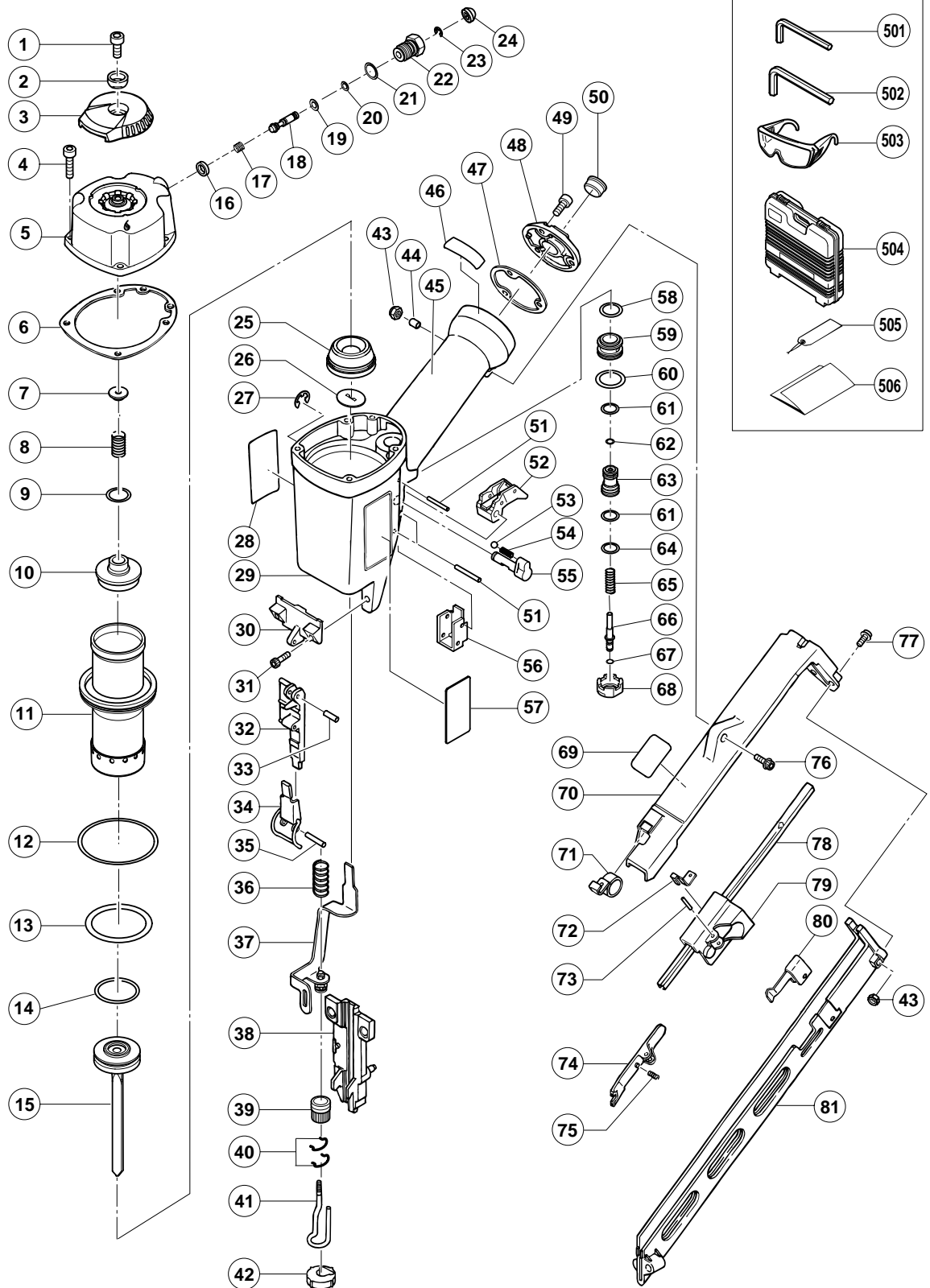

PARTS

NT 65MA2

ITEM NO.	CODE NO.	DESCRIPTION	NO. USED	REMARKS
1	949-657	HEX. SOCKET HD. BOLT M6X12 (10 PCS.)	1	
2	880-515	PLATE	1	
3	884-332	TOP COVER	1	
4	949-757	HEX. SOCKET HD. BOLT M5X20 (10 PCS.)	4	
5	884-331	EXHAUST COVER	1	
6	880-358	GASKET	1	
7	882-914	HEAD BUMPER	1	
8	882-913	HEAD VALVE SPRING	1	
9	876-796	O-RING (P-22)	1	
10	882-912	HEAD VALVE (A)	1	
11	884-329	CYLINDER	1	
12	877-312	CYLINDER O-RING (I.D 63.1)	1	
13	878-716	O-RING (P-46)	1	
14	882-685	O-RING (I.D 34.7)	1	
15	884-330	PISTON	1	
16	881-711	VALVE PACKING	1	
17	881-900	SPRING	1	
18	884-333	PLUNGER	1	
19	873-093	O-RING (1AP-3)	1	
20	881-715	O-RING (S3)	1	
21	987-105	O-RING (S-10)	1	
22	882-701	VALVE BUSHING	1	
23	968-643	RETAINING RING (E-TYPE) FOR D4 SHAFT	1	
24	884-334	KNOB	1	
25	881-741	PISTON BUMPER	1	
26	881-756	BUMPER SHEET	1	
27	955-479	RETAINING RING (E-TYPE) FOR D6 SHAFT	1	
28	884-070	WARNING LABEL	1	
29	884-328	BODY ASS'Y	1	INCLUD. 45
30	881-764	GUIDE PLATE (B)	1	
31	949-661	HEX. SOCKET HD. BOLT M6X30 (10 PCS.)	2	
32	881-743	GUIDE PLATE (A)	1	
33	949-770	ROLL PIN D4X14 (10 PCS.)	1	
34	884-323	LOCK LEVER	1	
35	949-685	ROLL PIN D3X20 (10 PCS.)	1	
36	877-894	HOLDER SPRING	1	
37	884-326	PUSHING LEVER (B)	1	
38	881-742	BLADE GUIDE	1	
39	884-325	ADJUSTER	1	
40	881-765	RATCHET SPRING	2	
41	884-324	PUSHING LEVER (A)	1	
42	881-751	NOSE CAP (A)	1	
43	877-371	NYLON NUT M5	3	
44	881-774	SLEEVE	1	
45		GRIP RUBBER	1	(SUPPLIED WITH ITEM NO. 607, 608)
46		CAUTION PLATE	1	
47	881-769	GASKET (B)	1	
48	881-758	CAP (A)	1	
49	949-821	HEX. SOCKET HD. BOLT M5X16 (10 PCS.)	3	
50	872-035	DUST CAP	1	
51	949-865	ROLL PIN D3X28 (10 PCS.)	3	

