

## PNEUMATIC TOOL PARTS LIST

■ STRIP NAILER  
Model NR 65AK

2001·9·14  
(E2)

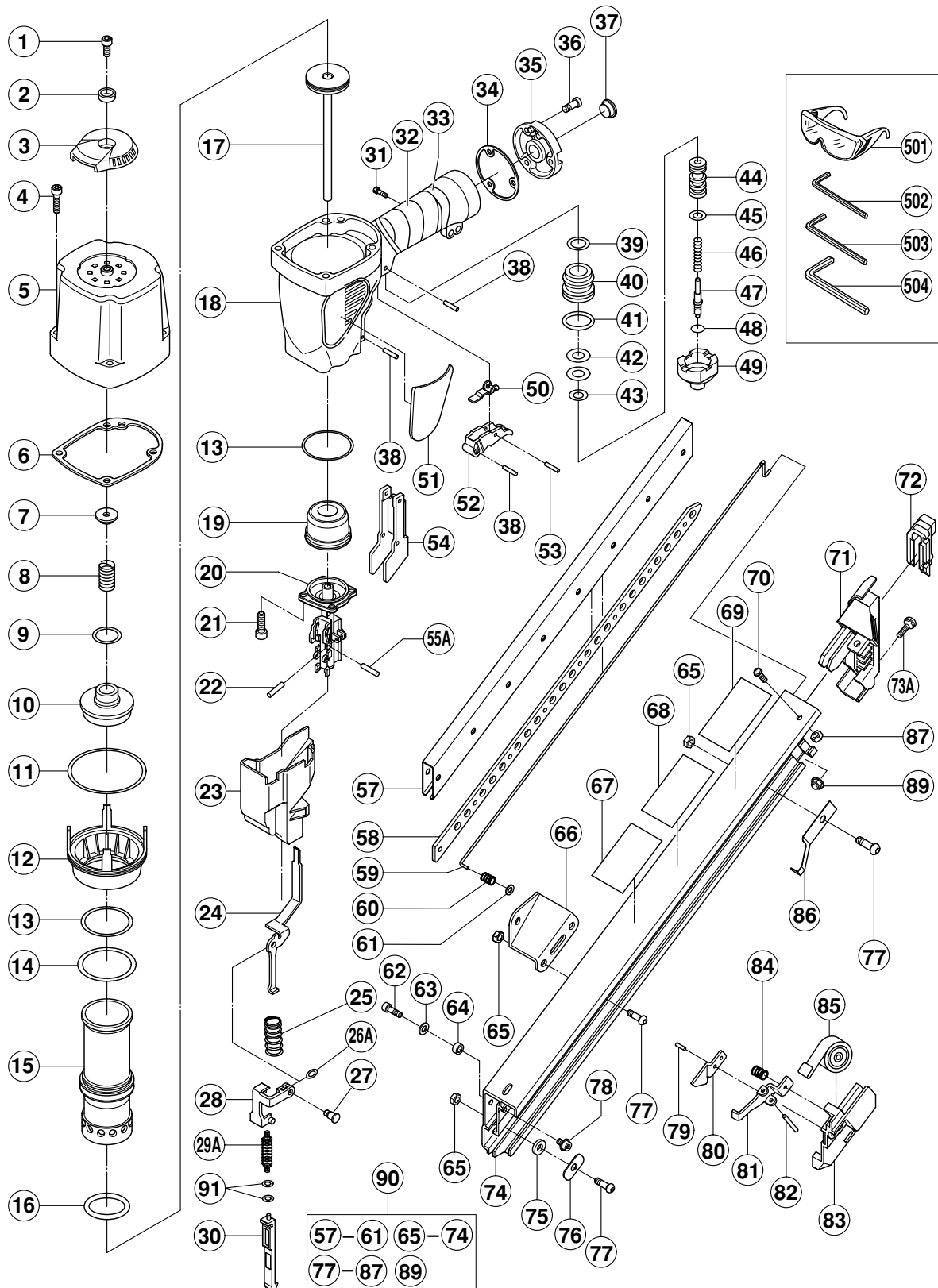

**PARTS**

NR 65AK

ITEM NO.	CODE NO.	DESCRIPTION	NO. USED	REMARKS
1	949-657	HEX. SOCKET HD. BOLT M6X12 (10 PCS.)	1	
2	880-515	PLATE	1	
3	880-514	TOP COVER	1	
4	949-822	HEX. SOCKET HD. BOLT M5X35 (10 PCS.)	4	
5	883-451	EXHAUST COVER	1	
6	883-452	GASKET (B)	1	
7	882-914	HEAD BUMPER	1	
8	882-913	HEAD VALVE SPRING	1	
9	876-796	O-RING (P-22)	1	
10	882-912	HEAD VALVE (A)	1	
11	878-863	O-RING (S-70)	1	
12	882-910	CYLINDER PLATE	1	
13	882-874	O-RING (S-46)	2	
14	877-368	O-RING (1AP-48)	1	
15	883-450	CYLINDER	1	
16	883-431	O-RING (I.D 37)	1	
17	883-430	PISTON (H)	1	
18	883-449	BODY ASS'Y	1	INCLUD.32,33
19	883-432	PISTON BUMPER	1	
20	883-433	NOSE	1	
21	880-675	NYLOCK HIGH TENSION BOLT M6X20	4	
22	949-535	ROLL PIN D3X12 (10 PCS.)	1	
23	883-447	GUARD	1	
24	883-445	PUSHING LEVER (C)	1	
25	883-446	PUSHING LEVER SPRING	1	
26A	873-093	O-RING (1AP-3)	1	
27	883-448	PIN (A)	1	
28	883-444	PUSHING LEVER (B)	1	
29A	883-470	SPRING	1	
30	883-443	PUSHING LEVER (A)	1	
31	880-474	NYLOCK BOLT (W/FLANGE) M6X16	1	
32	881-768	GRIP TAPE (A)	1	
33	880-407	TAPE	2	
34	881-769	GASKET (B)	1	
35	881-949	CAP	1	
36	949-821	HEX. SOCKET HD. BOLT M5X16 (10 PCS.)	3	
37	872-035	DUST CAP	1	
38	949-865	ROLL PIN D3X28 (10 PCS.)	3	
39	877-699	HEAD VALVE O-RING (I.D 16.8)	1	
40	878-881	VALVE BUSHING (B)	1	
41	878-885	O-RING (S-18)	1	
42	878-925	O-RING (I.D 8.8)	2	
43	878-887	O-RING (I.D 11)	1	
44	880-672	VALVE PISTON (B)	1	
45	981-317	O-RING (S-4)	1	
46	883-453	PLUNGER SPRING (B)	1	
47	880-673	PLUNGER (A)	1	
48	878-888	O-RING (I.D 1.8)	1	
49	880-671	VALVE BUSHING (A)	1	
50	883-454	TRIGGER ARM	1	
51		NAME PLATE	1	



