

REPLACEMENT PARTS

Ref. No.	Part No.	Description	Ref. No.	Part No.	Description
1	902581	M6 X 80MM CARRIAGE HD SCR	68	23-006	WHEEL DRESSER
2	901911	EYESHIELD	69	902645	WRENCH HOLDER
3	900227	FLAT WASHER	70	902590	WRENCH OPEN END 10MMX12MM
4	902582	M6 KNOB	74	1346828	LAMP ASSY
5	902583	SPACER	75	900843	WARNING LABEL
6	902584	RIGHT SPARK BREAKER	76	1343759	SWITCH
7	1320090	FLAT WASHER	78	1246007	M04 X 0.7 X 08 HEX SOC SET SCR
8	1340609	1/4"-20 X 1/4" HEX HD SCREW	79	1342734	KNOB
9	908948	KNOB	81	902647	VARIABLE SPEED LABEL
10	908949	R. H. COVER	82	902648	SWITCH PLATE
15	908955	FLANGE	83	904-02-020-1702	LOCK WASHER
16	23-269	WHITE FRIABLE GRINDING WHEEL	84	902-01-120-1034	1/4"-20 HEX NUT
18	908957	R. H. WHEEL GUARD	85	908970	CAPACITOR
19	900839	ROTATIONAL LABEL	87	908972	CAPACITOR CLAMP
20	901-02-120-7528	1/4"-20 X 1/2" SCREW	88	908971	CIRCUIT BOARD ASSY
21	1320828	TOOL REST ASSY	89	1343545	WASHER
22	904-02-010-1703	LOCK WASHER	90	1344955	M03.9 X 08 SCREW
23	901-01-060-0607	5/16"-18 X 3/4" HEX HD SCREW	91	1320217	PAD
24	904-01-010-1605	FLAT WASHER	92	1320087	WASHER
25	901-01-060-0606	5/16"-18 X 5/8" HEX HD SCREW	93	901-02-010-0525	10-24 X 1/2" ROUND HD SCREW
26	1340644	10-24 X 5/8" SCREW	94	902651	BASE COVER
27	908958	END BELL	100	908951	R. H. QUICK RELEASE NUT
28	1346461	M05 X 0.8 X 05 HEX SOC SET SCR	101	908966	L. H. QUICK RELEASE NUT
29	908959	PLATE	102	901930	HRDW PKG TOOL REST , INCL., REF. 18, 19, 20, 21 & 22
30	908960	SENSOR	103	903504	HRDW PKG, INCL., REF. 1, 3, 4, 5, 6, 7, 8, 19, 20, 21, 22, 27 & 69
31	902638	M3 X 6MM RD HD SCREW	**	909474	8" BUFFING WHEEL
33	905844	WARNING PLATE	**	909475	BUFFING WHEEL SPACER
40	902586	LEFT SPARK BREAKER	**	NOT SHOWN	
49	908964	L. H. WHEEL GUARD			
52	23-270	36G GRINDING WHEEL			
57	908968	L. H. COVER			
60	1320125	POWER CORD			
61	1320003	10-24 X 1/4" SCREW			
62	1320101	EXT TOOTH WASHER			
63	1310057	STRAIN RELIEF			
64	1320005	10-24 X 3/8" SCREW			
65	1320211	PLATE			
66	902643	M4 X 8MM PAN HD SCREW			
67	902644	DRESSER HOLDER			

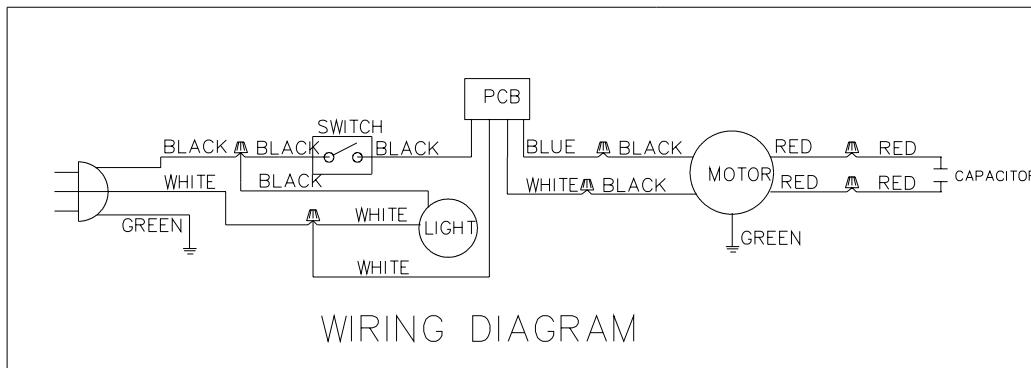

STANDARD SAFETY EQUIPMENT

In order to promote tool safety, Delta Machinery strictly enforces the policy of repairing or replacing any damaged or missing standard safety equipment on machines presented to Delta Authorized Service Centers for service/repairs. Any product that is presented to a Delta Authorized Service Centers for repairs which contains missing or damaged standard safety equipment will have that equipment repaired or replaced and the customer will be charged for any such service/repairs. Customers can avoid such charges only if the missing safety component is supplied to the service center at the time of repair.

This parts list is provided to aid in obtaining service parts. Copies of the instruction and maintenance literature can be obtained through the Delta Technical Publications Department or through your service outlet.