

REPLACEMENT PARTS

Ref.			Ref.		
No.	Part No.	Description	No.	Part No.	Description
1	1350244	LOCKING COLLAR	47	1350483	#10-24 X 3/8" FLAT HD SCR
2	1350246	SPRING			(ALUM CMO SEE NOTE A)
3	1350243	LOCKING ROD	47A	1350398	#10-24 X 3/8" FLAT HD SCR
4	1350245	KNOB			(EMO, SEE NOTE A)
5	1350403	1/4-20 X 1 1/8" HEX HD SCREW	48	1350538	#10-24 HEX NUT
6	1350280	1/4-20 LOCK NUT			(ALUM., CMO, SEE NOTE A)
7	1350406	#10-24 LOCK NUT	48A	1350397	#10-24 HEX NUT
8	1350253	UPPER LINKAGE ASSY			(EMO, SEE NOTE A)
9	1350241	COUNTERWEIGHT ASSY	49	1350396	#10-32 X 5/8" FLAT HD SCREW
10	1350249	KNOB	50	1350537	#10-24 X 5/8" FLAT HD SCR
11	1350248	10-24 X 1.5 EYE SCREW			(ALUM, CMO, SEE NOTE A)
12	1350247	SPRING	50A	1350407	#10-24 X 5/8" FLAT HD SCREW
13	1350260	KNOB			(EMO, SEE NOTE A)
14	1350259	BASKET GUIDE ASSY	51	1350347	SIDE PANEL
16	1350250	END CAP	52	1350538	#10-24 HEX NUT
17	1350303	1/4-20 X 1 1/2" HEX HD SCREW			(ALUM., CMO, SEE NOTE A)
18	1350280	1/4-20 LOCK NUT	52A	1350405	#10-24 LOCK NUT
20	1350267	BASKET ADJUSTMENT ASSY (78-959 & 78-960)			(EMO, SEE NOTE A)
20A	1351527	BASKET ADJUSTMENT ASSY (78-955 ONLY)	53	1350346	FRONT SWINGING PANEL
21	1350268	ADJUSTMENT SCREW	54	1350349	TOP PANEL
22	1350260	KNOB	*	78-966	DUST COLLECTOR ASSY,
23	1350326	GUARD MOUNT ASSY			(CMO), CONST OF:
23A	1350262	NAMEPLATE	55	1359009	WIRE TIE (CMO)
23B	1352171	WARNING LABEL (CMO)	56	1359008	VACUUM HOSE (CMO)
23C	1350812	WARNING LABEL (EMO)	57	1351859	DUST CHUTE (CMO)
24	1350269	CRANK HANDLE LOCKNUT	58	1351860	FRONT PANEL (CMO)
25	1350270	CRANK HANDLE	59	1350538	#10-24 HEX NUT
26	1350291	3/8-16 HEX NUT			(ALUM., CMO, SEE NOTE A)
27	1350245	KNOB	59A	1350537	#10-24 X 5/8" FLAT HD SCR
28	1350404	1/4-20 X 5/8" BUTTON HD SCREW			(ALUM, CMO, SEE NOTE A)
29	1350249	KNOB	*	78-956	DUST COLLECTOR ASSY,
30	1350271	CRANK HANDLE LATCH			(EMO), CONST OF:
31	1350297	#08 X 3/4" PAN HD SCREW	60	1359001	DUST CHUTE (EMO)
32	1350284	1/4-20 HEX NUT	61	1359006	WINDOW (EMO)
33	1350318	1/4" FLAT WASHER	62	1359008	VACUUM HOSE (EMO)
34	1350284	1/4-20 HEX NUT	63	1350538	#10-24 HEX NUT
35	1350318	1/4" FLAT WASHER			(EMO, SEE NOTE A)
36	1350318	1/4" FLAT WASHER	64	1350483	#10-24 X 3/8" FLAT HD SCR
37	1350319	1/4-20 X 3 3/4" HEX HD SCREW			(EMO, SEE NOTE A)
38	1350400	1/4-20 X 2 3/4" HEX HD SCREW	65	1359009	WIRE TIE (EMO)
39	1350318	1/4" FLAT WASHER	70	78-954	ADAPTER BRACKET, INCL:
40	1350272	END CAP			(SEE NOTE B)
41	1350242	LOWER LINKAGE	71	1350400	1/4-20 X 2 3/4" HEX HD SCREW
42	1350280	1/4-20 LOCK NUT	72	1350318	1/4" FLAT WASHER
43	1350403	1/4-20 X 1 1/8" HEX HD SCREW	73	1350293	1/4" LOCK WASHER
44	1350399	#10-32 LOCK NUT	74	1350284	1/4-20 HEX NUT
45	1350238	BASKET MOUNTING ASSY			
46	1350345	BASKET BODY	*		NOT SHOWN ASSEMBLED
					EMO=EARLY MODELS ONLY
					CMO=CURRENT MODELS

NOTE A: WHEN SERVICING, USE THREAD RETAINING COMPOUND. (*LOCITIE 425 RECOMMENDED*)

NOTE B: 78-954 ADAPTER BRACKET IS AVAILABLE TO MOUNT THE BIESEMEYER T-SQUARE 10" TABLE SAW BLADE GUARD SYSTEM TO SAWS EQUIPPED WITH THE DELTA 52" UNIFENCE.

**DELTA SPLITTER ASSY
(CURRENT MODELS ONLY)**

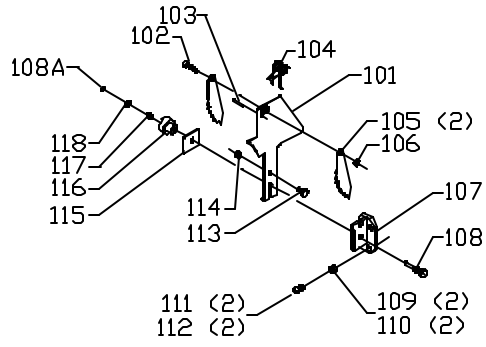

POWERMATIC 66 SPLITTER ASSY

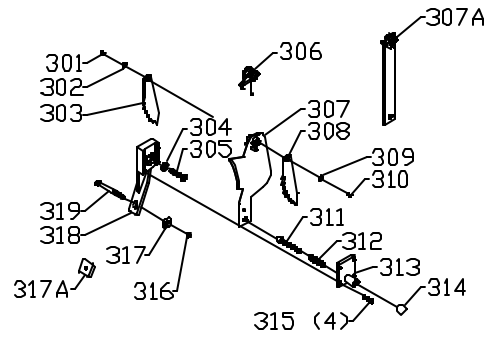

**DELTA SPLITTER ASSY
(EARLY MODELS ONLY)**

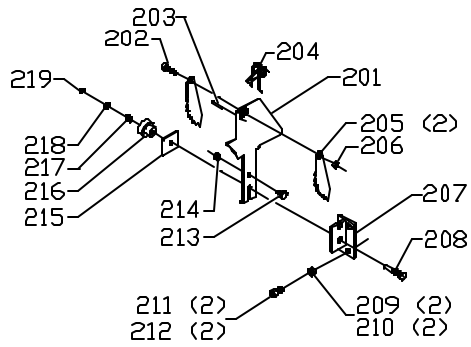

REPLACEMENT PARTS

Ref. No.	Part No.	Description	Ref. No.	Part No.	Description
DELTA SPLITTER ASSY (CURRENT MODELS ONLY)			POWERMATIC 66 SPLITTER ASSY		
*	1349941	SPLITTER ASSY COMPLETE, CONST (SEE NOTE C)	301	1350304	#10-32 X 1/4" PAN HD SCREW
101	1345159	SPLITTER ASSY, INCL:	302	1350276	FLAT WASHER
102	901-03-011-9976	#10-24 X 1" HEX SOC HD SCREW	303	1350321	ANTI-KICKBACK FINGER
103	1310311	(DIN 1481) M4 X 22MM SPRING PIN	304	1350418	3/8" INT TOOTH WASHER
104	1313276	SPRING	305	1350430	3/8-16 X 3/4" HEX HD SCREW
105	1313279	FINGER	306	1350320	SPRING
106	1349929	#10-24 LOCK NUT	307	1351644	SPLITTER ASSY (CMO)
107	1345166	SPLITTER MOUNT	308	1350321	ANTI-KICKBACK FINGER
108	1345118	STUD ASSEMBLY, INCL:	309	1350276	FLAT WASHER
108A	422-32-079-0001	E-RING	310	1350304	#10-32 X 1/4" PAN HD SCREW
109	1345122	BUSHING (USED W/10" UNISAW)	311	1351058	#10-32 X 7/8" HEX SOC HD SCREW
110	1345112	BUSHING (USED W/10" CONTRACTOR AND T/	312	1350084	SPRING
111	1349526	5/16-18 X 5/8" BUTTON HD SCREW (UNISAW)	314	1350085	KNOB
112	1345931	1/4-20 X 5/8" BUTTON HD SCREW (CON&TAS)	315	1350305	#8-32 X 1/2" HEX SOC HD SCREW
113	1345117	INDEX PIN	316	1350280	1/4-20 LOCK NUT
114	1345150	LOCK NUT	317	1351199	FLAT WASHER (CMO)
115	1345113	SPLITTER PLATE	319	1350277	1/4-20 X 1 3/4" HEX HD SCREW
116	1345115	KNOB			
117	1345116	SPRING	*		NOT SHOWN ASSEMBLED
118	904-01-031-5652	1/4" FLAT WASHER			EMO=EARLY MODELS ONLY
					CMO=CURRENT MODELS
DELTA SPLITTER ASSY (EARLY MODELS ONLY)			NOTE C: CURRENT MODELS SPLITTER ASSEMBLIES ACCOMMODATE		
*	1349941	SPLITTER ASSY COMPLETE, CONST (SEE NOTE C)	BOTH LEFT AND RIGHT BLADE TILT SAWS, AS SHOWN, THE SPLITTER IS CONFIGURED FOR RIGHT BLADE TILT SAWS. THE SPLITTER MUST BE ASSEMBLED IN REVERSE ORDER FOR LEFT BLADE TILT SAWS. REFER TO OWERNES MANUAL FOR SPECIFIC INSTRUCTIONS. FOR IDENTIFICATION, CURRENT MODELS HAVE FOUR 7/16" DIA. MOUNTING HOLES IN THE SPLITTER MOUNT REF #107.		
201	1345159	SPLITTER ASSY, INCL:	EARLY MODEL SPLITTER ASSEMBLIES ACCOMMODATED RIGHT BLADE TILT SWAS ONLY. FOR IDENTIFICATION, EARLY MODELS HAVE TWO 7/16" DIA. MOUNTING HOLES IN THE SPLITTER MOUNT REF #207.		
202	901-03-011-9976	#10-24 X 1" HEX SOC HD SCREW	EARLY AND CURRENT COMPLETE SPLITTER ASSEMBLIES		
203	1310311	(DIN 1481) M4 X 22MM SPRING PIN			
204	1313276	SPRING			
205	1313279	FINGER			
206	1349929	#10-24 LOCK NUT			
207	1345118	SPLITTER MOUNT ASSY			
208	1345122	STUD ASSEMBLY			
209	1345112	BUSHING (USED W/10" UNISAW)			
210	901-03-010-3350	BUSHING (USED W/10" CONTRACTOR & TAS)			
211	901-03-010-0229	5/16-18 X 1/2" HEX SOC HD SCREW (UNISAW)			
212	1345117	1/4-20 X 1/2" HEX SOC HD SCREW (CON&TAS)			
213	1345150	INDEX PIN			
214	1345113	LOCK NUT			
215	1345115	SPLITTER PLATE			
216	1345116	KNOB			
217	904-01-031-5652	SPRING			
218	1345149	1/4" FLAT WASHER			
219	1350304	RETAINING RING			

STANDARD SAFETY EQUIPMENT

In order to promote tool safety, Delta Machinery strictly enforces the policy of repairing or replacing any damaged or missing standard safety equipment on machines presented to Delta Authorized Service Centers for service/repairs. Any product which is presented to a Delta Authorized Service Centers for repairs which contains missing or damaged standard safety equipment will have that equipment repaired or replaced and the customer will be charged for any such service/repairs. Customers can avoid such charges only if the missing safety component is supplied to the service center at the time of repair.

This parts list is provided to aid in obtaining service parts. Copies of the instruction and maintenance literature can be obtained through the Delta Technical Publications Department or through your service outlet.