



# 43-431X, 43-437 & 43-495X 2-SPEED HEAVY DUTY WOOD SHAPER

# WS-2D-1A

PART NO. 432-02-651-0044

Dated: 09-17-03

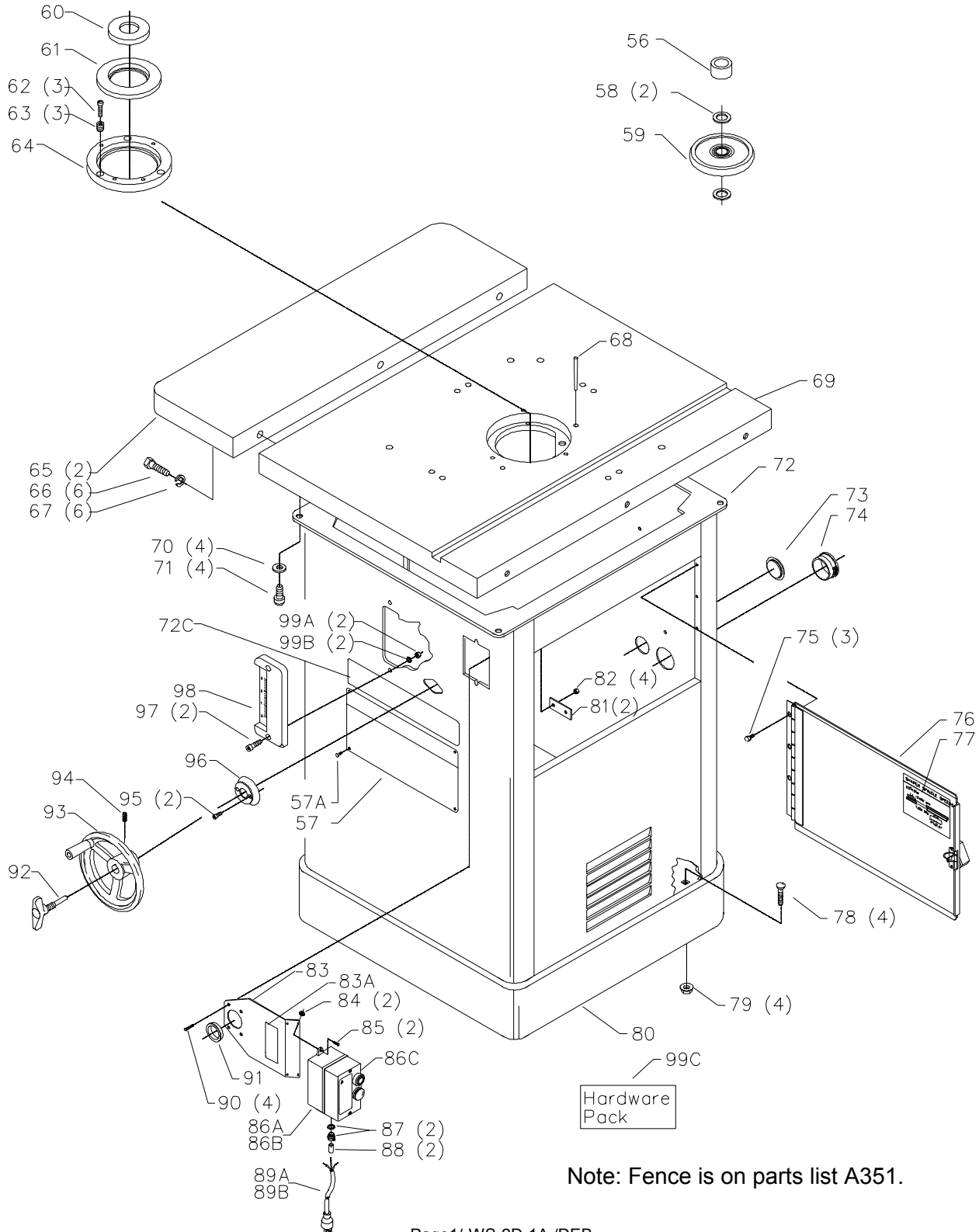

Note: Fence is on parts list A351.

# REPLACEMENT PARTS

<u>Ref.</u>	<u>No.</u>	<u>Part No.</u>	<u>Description</u>
	56	432-02-017-0004	BUSHNG
	57	n 432-02-137-0011	NAMEPLATE (SEE NOTE B), 43-437
		432-02-137-0007	NAMEPLATE (SEE NOTE A), 43-437
		n 432-02-137-0010	NAMEPLATE (SEE NOTE B), 43-431X, 43-495X
		432-02-137-0009	NAMEPLATE (SEE NOTE A), 43-431X, 43-495X
	57A	1087794	RIVET
	58	432-02-104-0008	SPACER (FOR 1/2 & 3/4" SPINDLES ONLY)
	59	43-440	4-1/2" SPINDLE GUARD
	60	432-02-063-0004	TABLE INSERT - SMALL
	61	432-02-063-0002	TABLE INSERT - INTERMEDIATE
	62	901-02-050-0725	1/4-20 X 1" FILL HD SCR
	63	432-02-112-0002	INSERT SCR
	64	432-02-063-0003	TABLE INSERT ASSY - OUTER
	65	36-937	EXTENSION WING, INCL:
	66	901-01-060-9964	7/16-20 X1 1/4" HEX HD SCR
	67	904-10-031-2097	WASHER
	68	905-03-013-1493	2-1/2" TAPER PIN
	69	432-02-391-0005	TABLE
	70	904-10-031-2097	WASHER
	71	901-03-010-1487	7/16-20 X3/4" HEX SOC HD SCR
	72	n 432-02-318-0019	CABINET ASSY (SEE NOTE B), INCL:
		432-02-318-0016	CABINET ASSY (SEE NOTE A), INCL:
	72C	432-02-137-0008	WARNING LABEL
	73	438-01-011-0065	PLUG
	74	438-01-011-0020	INSULATOR
	75	901-05-213-1498	#10 X 1/2" HEX WASHER HD SCR
	76	432-02-331-0013	DOOR ASSY, INCL:
	77	432-02-754-0006	SPEED CHART
	78	901-11-020-0834	5/16-18 X 3/4" CARRIAGE HD SCR
	79	902-01-503-1514	5/16-18 FLANGE NUT
	80	422-04-305-0001	SUB BASE
	81	432-02-072-0002	SWITCH RETAINER PLATE
	82	902-01-133-1529	1/4-20 FLANGE NUT
	83	432-02-014-0017	STARTER BRACKET, INCL.:
	83A	422-04-752-0185	LABEL
	84	902-01-293-1513	#10-32 KEPS NUT
	85	901-02-453-1123	#10-32 X 1/2" PAN HD SCR
	86A	438-01-016-0199	STARTER, GPE. 1HP, 200-230V, 3HP, INCL.:
	86B	438-01-016-0204	STARTER, GPE. 1HP,230V, 5HP, INCL.:
	86C	438-01-016-0200	COVER
	87	438-01-004-0007	CORD CLAMP
	88	438-01-011-0054	INSULATOR SLEEVE
	89A	438-01-302-2013	POWER CORD, 230V, 3HP
	89B	438-01-302-2004	POWER CORD, 230V, 5HP
	90	901-02-403-1131	1/4-20 X7/8" TRUSS HD SCR
	91	438-01-011-0051	INSULATOR
	92	422-04-412-0009	LOCK KNOB, 43-437
		422-04-412-0011	LOCK KNOB, 43-431X, 43-495X
	93	422-04-400-0005	HANDWHEEL, INCL., 43-437
		422-04-400-0007	HANDWHEEL, INCL., 43-431X, 43-495X
	94	901-04-190-0201	5/16-18 X 5/16" HEX SOC SET SCR
	95	901-03-010-3318	#10-32 X 3/8" HEX SOC HD SCR
	96	432-02-031-5002	COVER
	97	901-03-010-3345	1/4-20 X 1" HEX SOC HD SCR
	98	432-02-014-0001	BRACKET W/SCALE
	99A	902-01-120-1034	1/4-20 HEX NUT
	99B	904-03-030-1757	1/4" EXT TOOTH WASHER
	99C	432-02-626-0009	HARDWARE PACK

**NOTE A:** Used on units with S/N beginning 03I and below.

**NOTE B:** Used on units with S/N beginning 03H and above.

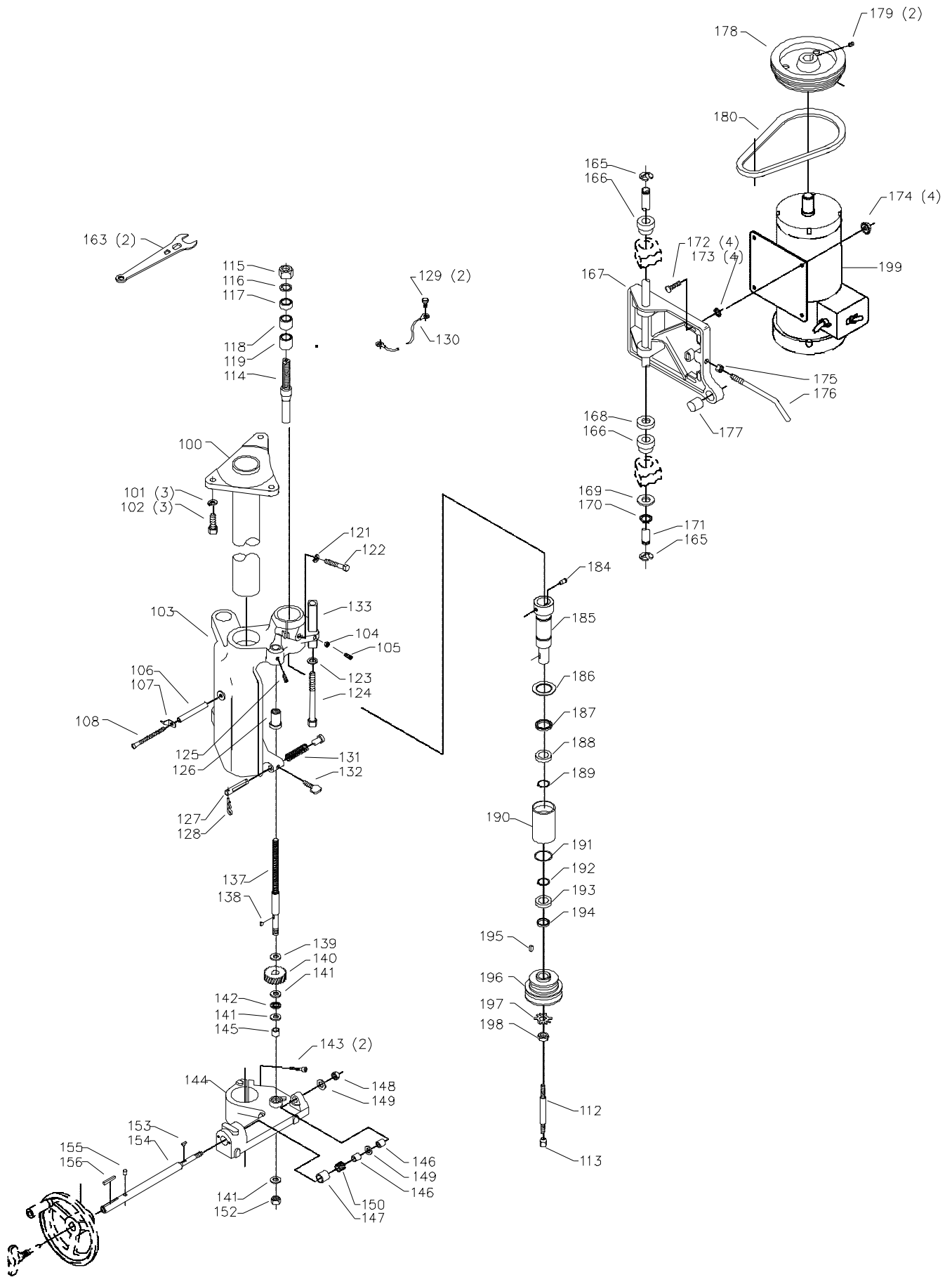

# REPLACEMENT PARTS

<u>Ref.</u>	<u>Part No.</u>	<u>Description</u>	<u>Ref.</u>	<u>Part No.</u>	<u>Description</u>
100	432-02-403-0002	FLANGE ASSY	155	422-04-074-0001	PLUG
101	904-02-020-1705	1/2" LOCK WASHER	156	927-03-010-2650	1-3/8" KEY
102	901-01-060-0672	1/2-20 X 1 1/4" HEX HD SCR	163	955-01-050-1467	WRENCH, (FOR 3/4" SPINDLE)
103	432-02-012-0007	SPINDLE HSG ASSY, CONST. OF:	165	904-15-060-7443	EXT RET RING
104	902-01-010-1300	5/16-18 HEX NUT	166	932-01-010-2860	BUSHING
105	901-04-193-1403	5/16-18 X 1" SET SCREW	167	432-02-005-0001	MOTOR PLATE
106	432-02-104-5001	SPACER	168	432-02-079-5001	RETAINER
107	422-04-075-5001	POINTER	169	904-01-010-1611	13/16" FLAT WASHER
108	901-02-013-1813	5/16-18 X 3 1/2" ROUND HD SCR	170	928-07-010-7378	FINGER SPRING WASHER
112	432-02-112-0003	TIE ROD	171	432-02-106-0001	SHAFT
113	902-01-201-2584	5/16-18 HEX NUT	172	901-11-020-0830	5/16-18 X 1 1/4" CAR. HD SCR
114	43-806	3/4" SPINDLE ASSY, INCL:	173	904-03-030-1656	5/16" EXT TOOTH WASHER
115	902-01-131-3082	.76-14 HEX NUT	174	902-01-503-1514	5/16-18 FLANGE NUT
116	904-05-010-6662	3/4" LOCK WASHER	175	902-01-201-2579	7/16-14 HEX NUT
117	904-10-031-4506	1-1/4 X 1/2" COLLAR	176	432-02-067-0002	LEVER
118	904-10-031-4507	1-1/4 X 3/4" COLLAR	177	432-02-016-5001	BUMPER
119	904-10-031-4508	1-1/4 X 1" COLLAR	178	432-02-430-0003	MOTOR PULLEY ASSY, INCL:
121	904-02-020-1704	3/8" LOCK WASHER	179	901-04-150-0206	5/16-18 X 5/16" SET SCR
122	901-01-060-0646	3/8-16 X 2" HEX HD SCR	180	432-02-133-0001	POLY V-BELT
123	904-01-031-2905	FLAT WASHER	*	432-02-385-0011	SPINDLE ASSY, CONST OF:
124	901-01-060-0685	1/2-20 X 5" HEX HD SCR	184	432-02-071-0003	DRIVE PIN
125	901-04-190-0201	5/16-18 X 5/16" SET SCREW	185	432-02-105-0003	FLANGE
126	432-02-105-5002	RAISING NUT	186	432-02-103-0002	FLANGE
127	432-02-071-0001	PIN	187	432-02-079-0002	NUT
128	905-05-040-2106	1/8" X 1 1/4" COTTER PIN	188	920-04-033-1821	BALL BEARING
129	901-03-010-3318	#10-32 X 3/8" HEX SOC HD SCR	189	904-15-013-1819	EXT RET RING
130	438-01-320-0258	JUMPER WIRE	190	432-02-077-0001	QUILL
131	432-02-122-0001	SPRING	191	904-04-013-1820	WAVE WASHER
132	901-04-260-1528	5/16-18 X 1" THUMB SCR	192	904-15-013-1819	EXT RET RING
133	432-02-110-5001	HEX GUIDE POST	193	920-04-033-1821	BALL BEARING
*	432-02-314-0010	ELEVATING ASSY, CONST OF:	194	432-02-104-0012	SPACER
137	432-02-112-0001	VERTICAL RAISING SCR	195	927-01-100-2606	KEY
138	927-01-010-2633	WOODRUFF KEY	196	432-02-130-0006	SPINDLE PULLEY
139	904-01-031-2905	FLAT WASHER	197	432-02-079-0001	RETAINER
140	432-02-051-0002	SPIRAL GEAR	198	902-07-030-7171	.802-28 BEARING NUT
141	920-76-033-1392	THRUST BEARING	199	n 82-006	3HP 1PH 230V MOTOR
142	920-45-013-1412	THRUST BEARING			
143	901-03-010-0760	1/4-20 X 1 1/4" HEX SOC HD SCR			
144	432-02-314-0009	BRACKET ASSY, INCL:			
145	920-75-013-1524	BEARING			
146	920-75-013-1523	BEARING			
147	920-75-011-2784	SLEEVE BEARING			
148	902-01-213-1635	3/8-16 LOCK NUT			
149	920-76-033-1391	SPECIAL WASHER			
150	432-02-051-0001	SPIRAL GEAR			
152	902-01-281-7295	1/4-20 HEX NUT			
153	927-01-010-2631	KEY			
154	432-02-106-0002	HORIZONTAL RAISING SCR			

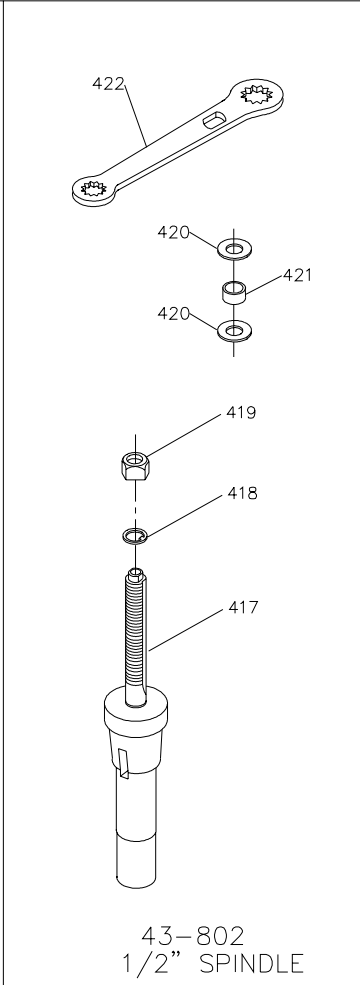
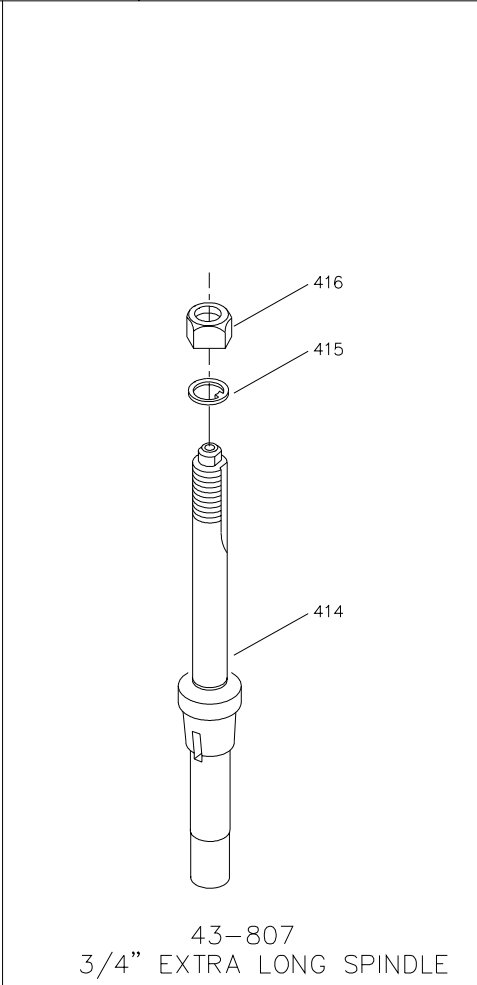
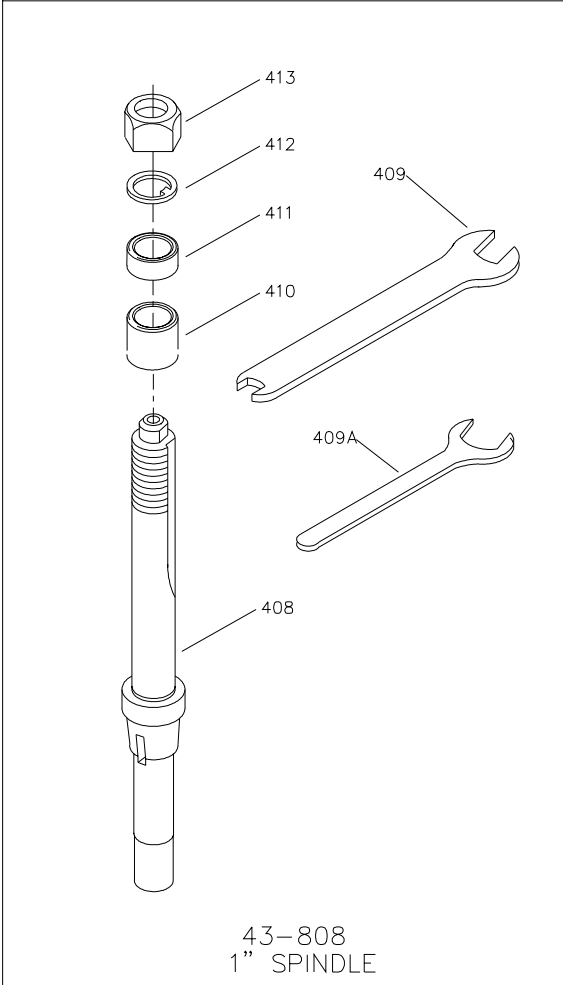
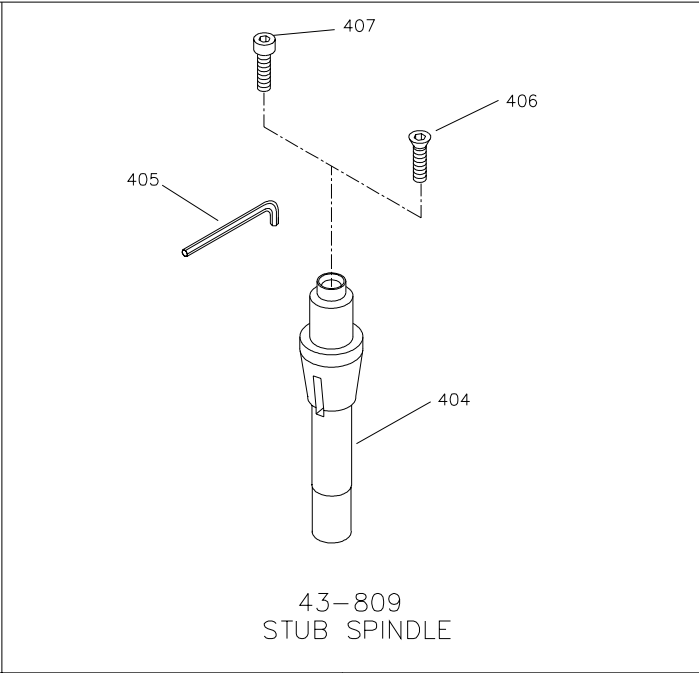
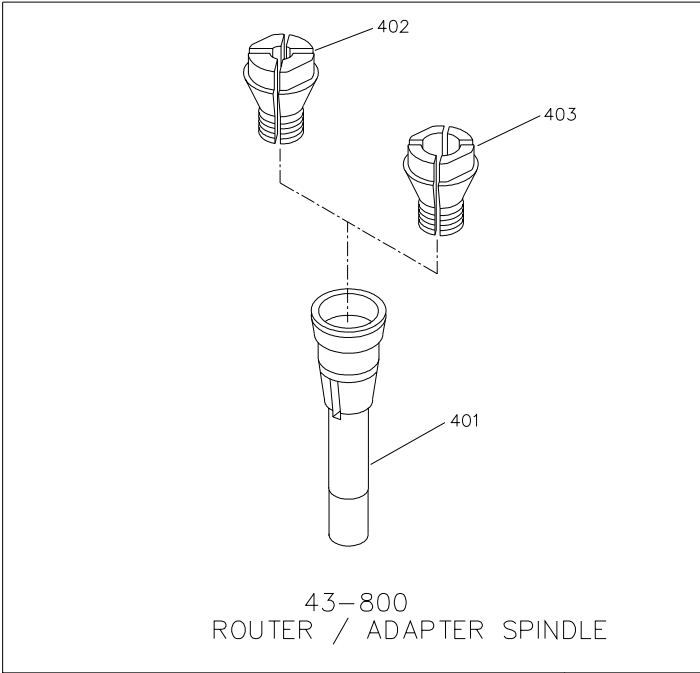

# REPLACEMENT PARTS

**Ref.**

<b>No.</b>	<b>Part No.</b>	<b>Description</b>
401	43-800	ROUTER ADAPTER SPINDLE, INCL:
402	58939	1/4" COLLET
403	18051	1/2" COLLET

ACCESSORIES: (Optional)

404	43-809	STUB SPINDLE, INCL: REF 112 &
405	955-03-010-0010	7/32" HEX WRENCH
406	901-03-100-6144	5/16-18 X 1 1/8" FLAT HD SCR
407	901-03-100-6139	5/16-18 X .86 HEX SOC HD SCR
408	43-808	1" SPINDLE, INCL:
409	955-01-040-1485	WRENCH
409A	404-01-101-5001	WRENCH
410	432-02-105-0005	1" COLLAR
411	432-02-105-0004	1/2" COLLAR
412	904-05-010-6674	SPECIAL KEYED WASHER
413	902-01-201-8553	1.00-14 HEX NUT
414	43-807	3/4" EXTRA LONG SPINDLE, INCL:
415	904-05-010-6662	3/4" LOCK WASHER
416	902-01-131-3082	.76-14 HEX NUT
417	43-802	1/2" SPINDLE, INCL: REF. 112 &
418	904-05-010-1646	3/4" WASHER
419	902-01-201-2575	.50-16 HEX NUT
420	432-02-104-0008	SPACER
421	432-02-017-0004	BUSHING
422	955-01-020-0023	.567" X .88" BOX END WRENCH

\* NOT SHOWN ASSEMBLED

---

## STANDARD SAFETY EQUIPMENT

In order to promote tool safety, Delta Machinery strictly enforces the policy of repairing or replacing any damaged or missing standard safety equipment on machines presented to Delta Authorized Service Centers for service/repairs. Any product that is presented to a Delta Authorized Service Centers for repairs which contains missing or damaged standard safety equipment will have that equipment repaired or replaced and the customer will be charged for any such service/repairs. Customers can avoid such charges only if the missing safety component is supplied to the service center at the time of repair.

*This parts list is provided to aid in obtaining service parts. Copies of the instruction and maintenance literature can be obtained through the Delta Technical Publications Department or through your service outlet.*