

REPLACEMENT PARTS

Ref.			Ref.		
No.	Part No.	Description	No.	Part No.	Description
1	1237393	TENSION LABEL	59	1350291	3/8" - 16 HEX NUT
2	912454	HANDLE	60	912529	PIN
3	912455	WASHER	61	1350291	3/8" - 16 HEX NUT
4	912459	SPRING	62	904-03-063-1134	3/8" WASHER
4A	912576	POINTER	63	904-01-010-1605	3/8" FLAT WASHER
5	1352277	SQUARE NUT	64	904-01-010-1605	3/8" FLAT WASHER
6	912460	UPPER WHEEL BRACKET	65	1350291	3/8" - 16 HEX NUT
7	912461	SCREW	66	912456	3/16" X 24 SCREW
8	912463	BEARING	67	912457	BRUSH
9	912465	UPPER WHEEL	68	902-01-010-1206	5/16" - 24 HEX NUT
10	912466	TIRE	69	912569	BASE
11	912464	C-RING	70	904-01-010-1605	3/8" FLAT WASHER
12	912463	BEARING	71	1350292	3/8" X 16 X 1 HEX HEAD SCREW
13	1313047	1/2" - 20 HEX NUT	72	1243398	M8 HEX NUT
14	912467	UPPER WHEEL GUARD	73	912452	5/16" WASHER
15	912468	PIN	74	1350308	5/16" FLAT WASHER
16	1237318	SPEED CHART	75	912579	RUBBER ISOLATOR
17	912256	NAME PLATE	76	1350308	5/16" FLAT WASHER
17A	912496	WARNING LABEL	77	912452	5/16" WASHER
18	904-02-020-1702	1/4" LOCK WASHER	78	1243398	M8 HEX NUT
19	901-03-010-0229	1/4" X 20 HEX SOC HD SCREW	79	912570	KNOB
20	912469	LOWER GUARD	80	912518	KNOB
21	SEE CATALOG	BLADE	81	912519	MOTOR BASE
22	902-01-020-9101	3/4" - 16 HEX NUT	82	912525	MOTOR PULLEY
23	912563	3/4" WASHER	83	901-01-060-0609	5/16"-18 X 1 HEX HD SCREW
24	912466	TIRE	84	904-02-020-1702	1/4" LOCK WASHER
25	912471	LOWER WHEEL	85	1350308	5/16" FLAT WASHER
26	912473	PULLEY	86	912527	ADJUSTING SCREW
27	912472	BELT	87	912528	BEARING HOUSING
28	912474	SHAFT	88	902-01-010-9104	3/4" - 16 HEX NUT
29	902-01-020-9101	3/4" - 16 HEX NUT	89	912526	COVER
30	912475	UPPER WHEEL SHAFT	90	901-04-141-9152	1/4"-20 X 3/8" HEX SOC SET SCREW
31	912476	KEY	91	912571	1/4" WASHER
32	912502	BEARING	92	912572	1/4" LOCK WASHER
33	1350284	1/4" - 20 HEX NUT	93	428-06-079-0004	KEY
34	1350294	1/4" X 20 x 3/4" HEX HD SCR	94	912520	MOTOR ASSY
35	912462	NUT	95	A00439	RUN CAPACITOR
36	912477	5/8" WASHER	96	A00441	START CAPACITOR
37	902-01-010-5446	5/8" - 11 HEX NUT			
38	1235059	3/16" X 24 PAN HD SCREW			
39	910925	SWITCH			
41	912564	SCREW			
41A	904-03-030-1795	3/16" WASHER			
42	902-01-010-1206	5/16" - 24 HEX NUT			
43	1350409	5/16" - 18 HEX NUT			
44	912478	KNOB			
45	1237328	SCALE			
46	912523	RETAINER			
47	912521	CORD			
48	912524	KNOB			
49	901-04-140-9406	1/4" X 20 SOC HD SCREW			
49A	1347433	WARNING LABEL			
50	912561	3/16" X 24 PAN HEAD SCREW			
50A	1320211	CORD CLAMP			
51	912567	WRENCH HOLDER			
52	912578	SHAFT			
53	912568	KNOB			
54	912522	CORD			
56	1346212	3/8" X 16 HEX HD SCREW			
57	904-01-010-1605	3/8" FLAT WASHER			
58	901-01-060-3113	3/8" X 16 HEX HD SCREW			
58A	912577	SPRING CLIP			

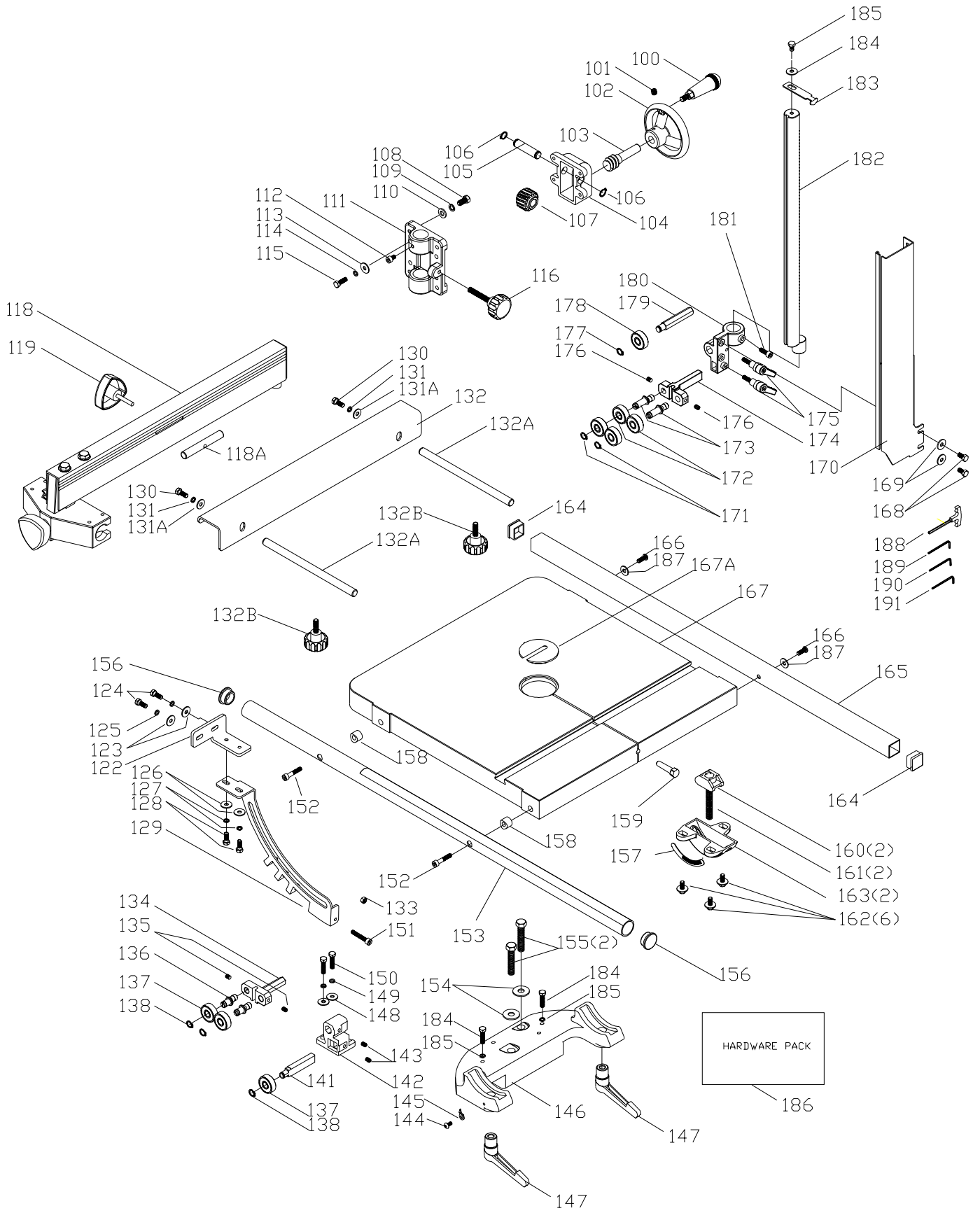

REPLACEMENT PARTS

Ref. No.	Part No.	Description	Ref. No.	Part No.	Description
100	912570	KNOB	153	912557	RAIL
101	901-04-160-1103	5/16" X 18 X 5/8" HEX SOC SET SCRI	154	904-01-010-1605	3/8" FLAT WASHER
102	912479	HAND WHEEL	155	901-01-060-0646	3/8" X 16 X 2 HEX HD SCREW
103	912516	WORM GEAR	156	912556	CAP
104	912480	GEAR BOX	157	1237375	SCALE
105	912515	GEAR SHAFT	158	912548	SPACER
106	912560	C-RING	159	912542	PIN
107	912481	GEAR	160	912543	CLAMP SHOE
108	901-01-060-0607	5/16"-18 X 3/4" HEX HD SCREW	161	901-01-060-0644	3/8" X 16 X 2 1/2" HEX HD SCREW
109	904-02-020-1702	1/4" LOCK WASHER	162	1350294	5/16"-18 X 3/4" HEX SOC HD SCREW
110	1350308	5/16" FLAT WASHER	163	912544	TRUNNION
111	912482	BRACKET	164	912575	REAR RAIL CAP
112	901-04-140-9406	1/4"-20 X 3/4" SOC HEAD SCR	165	912540	RAIL
113	904-02-020-1702	1/4" LOCK WASHER	166	901-04-153-1794	1/4" X 20 X 1" HEX SOC HD SCREW
114	904-02-020-1702	1/4" LOCK WASHER	167	912541	TABLE
115	1350294	1/4"-20 X 3/4" HEX HD SCREW	167A	912549	TABLE INSERT
116	912517	KNOB	168	901-02-010-0514	1/4" X 20 X 3/8" HEX HD SCREW
118	912552	FENCE ASSEMBLY	169	904-01-010-1603	1/4" FLAT WASHER
118A	912550	GUIDE BAR	170	912532	BLADE COVER
119	912551	KNOB	171	912536	C-RING
122	912580	BASE	172	912535	BEARING
123	1350312	1/4" FLAT WASHER	173	912537	SHAFT
124	1350294	1/4"-20 x 3/4" L HEX HD SCR	174	912538	SUPPORT
125	904-02-020-1702	1/4" LOCK WASHER	175	912539	KNOB
126	904-01-010-1603	1/4" FLAT WASHER	176	901-04-141-9152	1/4"-20 X 3/8" HEX SOC SET SCREW
127	904-02-020-1702	1/4" LOCK WASHER	177	912536	C-RING
128	1350294	1/4"-20 x 3/4" L HEX HD SCR	178	912535	BEARING
129	912581	BRACKET	179	912534	BEARING SUPPORT BRACKET
130	1350294	1/4"-20 x 3/4" L HEX HD SCREW	180	912533	BRACKET
131	904-02-020-1702	1/4" LOCK WASHER	181	1350294	1/4"-20X 3/4" HEX HD SCREW
131A	1350312	1/4" FLAT WASHER	182	912531	GUIDE BAR
132	912573	EXTENSION TABLE	183	912530	POINTER
132A	912574	EXTENSION BAR	184	901-04-261-4005	18 X 2 1/2 X 5/16" BOLT
132B	912570	KNOB	185	901-04-141-9152	1/4" - 20 X 3/8" HEX SOC SET SCREW
133	1350284	1/4" - 20 HEX NUT	186	912871	HARDWARE PACK
134	912538	SUPPORT	187	904-02-020-1702	1/4" LOCK WASHER
136	912558	GUIDE SHAFT	188	912562	HEX WRENCH, 3MM
137	912535	BEARING	189	912565	HEX WRENCH, 5MM
138	912536	C-RING	190	428-06-101-0002	HEX WRENCH, 3MM
141	912534	BEARING SUPPORT	191	428-07-101-0002	HEX WRENCH, 6MM
142	912559	BRACKET			
143	901-04-141-9152	1/4"-20 X 3/8" HEX SOC SET SCREW			
144	912453	3/16" X 24 X 3/8" PAN HD SCREW			
145	912547	POINTER			
146	912545	TABLE BRACKET			
147	912546	KNOB			
148	904-01-010-1603	1/4" FLAT WASHER			
149	904-02-020-1702	1/4" LOCK WASHER			
150	1350302	1/4"-20X 1" HEX HD SCREW			
151	901-01-060-0622	1/4" X 20 X 2 SOC HD SCREW			
152	901-03-013-1069	1/4" X 20 X 1 1/2 HEX SOC HD SCREW			

STANDARD SAFETY EQUIPMENT

In order to promote tool safety, Delta Machinery Corp. strictly enforces the policy of repairing or replacing any damaged or missing standard safety equipment on machines presented to Delta Authorized Service Centers for service/repairs. Any product which is presented to a Delta Authorized Service Centers for repairs which contains missing or damaged standard safety equipment will have that equipment repaired or replaced and the customer will be charged for any such service/repairs. Customers can avoid such charges only if the missing safety component is supplied to the service center at the time of repair.

This parts list is provided to aid in obtaining service parts. Copies of the instruction and maintenance literature can be obtained through the Delta Technical Publications Department or through your service outlet.