

POS. NO.	PART NO.	QTY.	DESCRIPTION	POS. NO.	PART NO.	QTY.	DESCRIPTION
1	See Pos #801	1	Motor housing	60	2 600 100 039	2	Shim 0.5mm
2	2 604 220 479	1	Field 115V	61	1 601 099 010	1	Depth lens
3	See Pos #803	1	Armature 115V	62	1 900 905 016	1	Ball bearing
4	2 607 200 255	1	Switch	63	1 600 100 631	1	Shim 0.5mm
5	3 604 460 555	1	Cord	65	See Pos#870	1	Spindle
6	2 600 703 008	1	Strain relief	66	2 601 098 013	1	Cover plate
7	2 601 035 001	1	Cord clamp	70	See Pos #870	1	Cutter drum
8	1 601 106 999	1	Name plate	71	2 608 040 039	2	Pressure bar ass'y w/Pos 71, 86, 87, 88
9	2 601 110 806	1	Label (3258)	72	2 603 320 003	1	Nut R.H.
10	See Pos #810	2	Carbon brush	73	2 603 342 006	1	Nut L.H.
13	1 900 905 023	1	Ball bearing	A74	2 607 000 096	1	Blade set
14	1 900 905 016	1	Ball bearing	+75	1 603 100 036	1	Rubber buffer
16	2 604 449 026	2	Brush holder	+77	2 605 510 036	4	Cutter drum caps
18	2 603 410 001	4	Screw	+79	2 600 300 055	1	Bushing
19	2 910 611 019	14	Screw	85	1 600 410 003	1	Protective strip
20	1 601 110 481	1	Label (Caution)	86	2 603 400 014	4	Set screw
25	2 600 100 588	1	Washer	87	2 603 450 005	6	Screw
26	2 600 324 009	1	Drive pulley	88	See Pos #71	2	Plate
27	2 606 625 009	1	Driven pulley	A700	1 608 132 006	1	Rabbeting depth stop
28	1 604 736 004	1	Drive belt	700/1	See Pos #700	1	Bracket
29	1 600 206 025	1	Rubber ring	700/2	1 603 481 009	1	Knob
30	2 910 611 005	4	Screw	700/3	2 916 011 014	1	Washer
31	1 600 190 016	2	Clamping plate	700/4	1 610 210 043	1	O-ring
32	1 600 591 006	1	Baffle	A704	2 607 001 078	1	Parallel angle fence
33	1 605 510 140	1	Belt cover	704/1	See Pos #704	1	Bracket
34	1 605 510 141	1	Side cover	704/2	2 608 010 004	1	Arm
36	1 605 510 142	1	Protective cover	704/3	See Pos #704	1	Fence
37	2 608 000 059	1	Adjusting shoe	704/4	2 914 401 401	1	Screw
38	See Pos #801	1	Base plate	704/5	2 918 640 006	1	Washer
39	2 606 621 001	1	Graduated dial	704/6	1 603 339 005	1	Knob
40	3 603 450 005	1	Bolt	704/7	2 910 021 158	2	Screw
41	2 910 601 320	4	Screw	704/9	2 603 339 002	2	Knob
42	1 604 619 017	1	Spring	704/10	See Pos #704	2	Pin
43	3 603 342 003	1	Adjusting nut	704/11	2 603 480 004	1	Knob
44	3 600 100 005	2	Shim 0.5mm	704/12	1 600 309 013	1	Spacer
47	1 605 510 139	1	Protective cover	704/13	1 610 210 043	1	O-ring
48	2 604 651 002	1	Spring	704/14	2 915 011 006	2	Nut
49	2 604 448 151	2	Cable	A706	1 605 411 022	1	Chip bag
50	2 915 011 007	3	Nut	A708	1 607 000 154	1	Vacuum connector
51	1 601 099 011	1	Slide	801	2 605 104 889	1	Motor housing ass'y w/ Pos 1, 19, 38, 41, 56, 59
52	1 601 006 006	1	Return band	803	2 604 010 762	1	Armature w/fan 115V
53	2 603 320 004	1	Nut	810	2 604 321 905	1	Brush set
A54	2 607 950 504	1	Open wrench 8mm	870	2 603 204 903	1	Cutter drum ass'y w/Pos 65, 66, 70, 71, 74, 86, 87, 88
A54.1	1 907 950 003	1	Allen wrench 2.5mm				
55	1 600 502 011	1	Rubber ring				
56	2 600 910 001	1	Needle bearing				
58	2 917 760 073	1	Roll pin				
59	2 605 500 087	1	Handle cover				

Service Notes

1 608 132 006

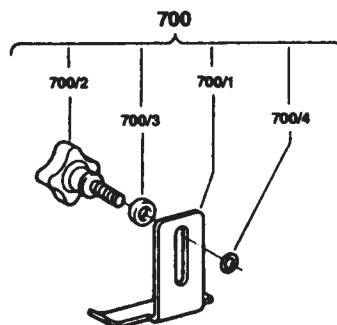

2 607 001 078

