

BOSCH

May 1997
INDUSTRIAL

SDS CHIPPING ADAPTOR

Model 0611999001

2 607 018 296

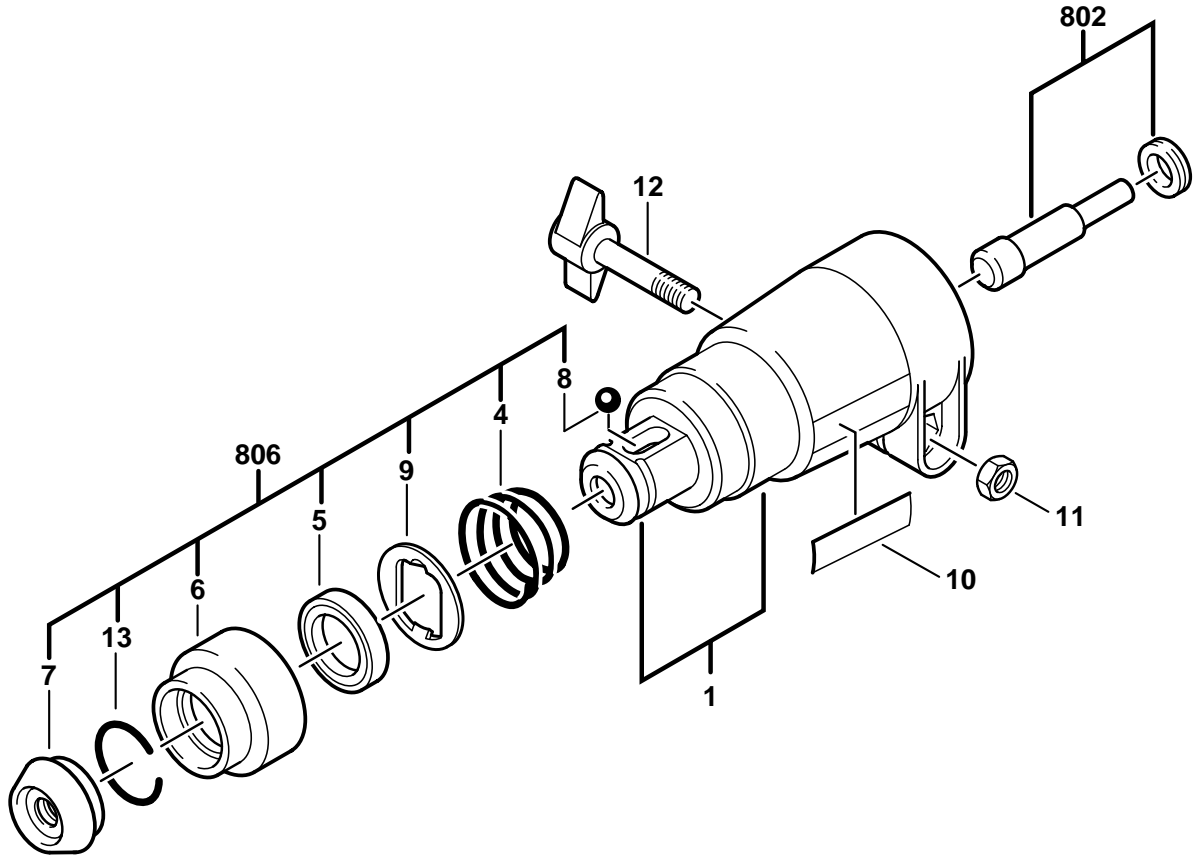

| Pos. | Part Number | Description {Qty} | F/C | Pos. | Part Number | Description {Qty} | F/C |
|------|---------------|------------------------|-----|------|---------------|------------------------------------------|-----|
| 1 | 3 615 102 006 | Housing w/Drill Holder | 83 | 10 | 1 611 110 250 | Label "Bosch" | 9 |
| 4 | 1 614 643 003 | Spring | 27 | 11 | 2 915 011 007 | Nut | 89 |
| 5 | 1 610 102 025 | Washer | 86 | 12 | 3 613 480 001 | Wing Screw | 89 |
| 6 | 1 610 499 012 | Plastic Sleeve | 92 | 13 | 2 916 540 012 | Spring Ring | 89 |
| 7 | 1 610 508 008 | Dust Shield | 92 | 802 | 3 617 031 025 | Impact Bolt assembly | 45 |
| 8 | 1 903 230 013 | Ball 7mm | 66 | 806 | 1 617 000 163 | Bit Retaining Assembly w/pos. 4-9, 13 | 86 |
| 9 | 1 610 190 011 | Holding Plate | 86 | | | | |

+ = Not Illustrated * = As Required F/C = Failure Code AW = Refer to AW Labor Time Chart