

BOSCH

April 1998
INDUSTRIAL

CHUCK ADAPTOR

Model 1617000998

2 607 000 186

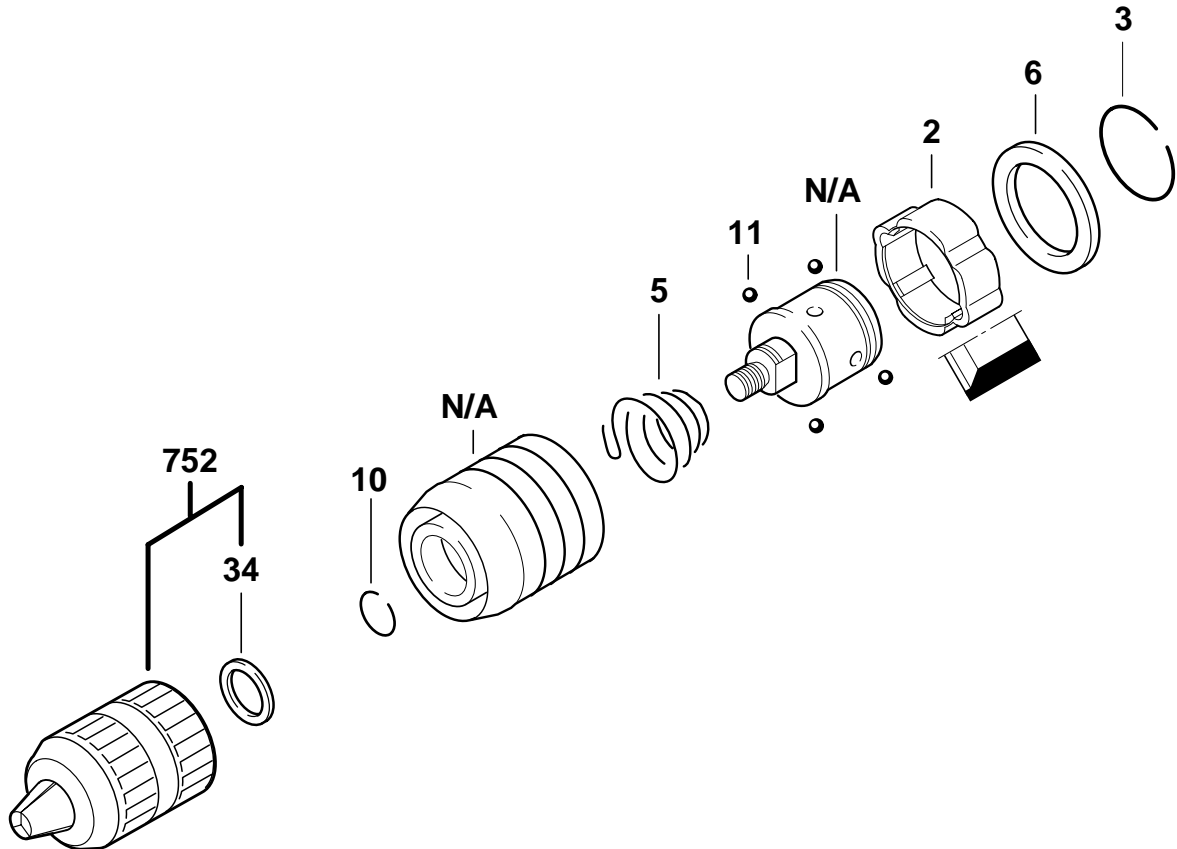

| Pos. | Part Number | Description {Qty} | F/C | Pos. | Part Number | Description {Qty} | F/C |
|------|---------------|-------------------|-----|------|---------------|--------------------------|-----|
| 2 | 1 610 290 044 | Locking Sleeve | 86 | 11 | 1 903 230 013 | Ball 7mm {4} | 66 |
| 3 | 1 614 601 016 | Spring Ring | 89 | 34 | 3 600 101 507 | Washer | 65 |
| 5 | 1 614 643 008 | Spring | 27 | 752 | 3 608 571 517 | 1/2" Keyless Chuck | 91 |
| 6 | 1 610 102 039 | Washer | 65 | | | w/pos. 34 | |
| 10 | 2 916 540 012 | Spring Ring | 89 | N/A | | Not Available Separately | |

+ = Not Illustrated * = As Required F/C = Failure Code AW = Refer to AW Labor Time Chart

S-B Power Tool Company Chicago IL 60646-5999